

# PACCAR MX-13

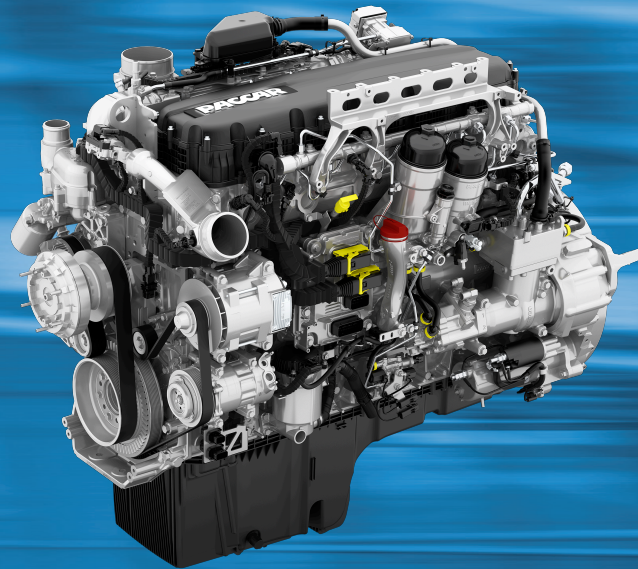

## Operator's Manual

2021 Emissions  
2021 Model Year Warranty



**Starting and Operating**

**1**

**Maintenance**

**2**

**Information**

**3**



## © 2021 PACCAR Inc. - All Rights Reserved

This manual illustrates and describes the operation of features or equipment which may be either standard or optional on this vehicle. This manual may also include a description of features and equipment which are no longer available or were not ordered on this vehicle. Please disregard any illustrations or descriptions relating to features or equipment which are not on this vehicle. PACCAR reserves the right to discontinue, change specifications, or change the design of its vehicles at any time without notice and without incurring any obligation. The information contained in this manual is proprietary to PACCAR. Reproduction, in whole or in part, by any means is strictly prohibited without prior written authorization from PACCAR Inc.

# Chapter 1 | STARTING AND OPERATING

Safety - Introduction.....	5
Emergency - What To Do If.....	10
Operating Instructions.....	13

## Safety - Introduction

### Using this Manual

Please take the time to get acquainted with your vehicle by reading this Operator's Manual. We recommend that you read and understand this manual from beginning to end before you operate this equipment. This manual contains useful information for the safe and efficient operation of this equipment. It also provides service information, with an outline for performing safety checks and basic preventive maintenance inspections. We have tried to present the information you'll need to learn about functions, controls, and operation—and to present it as clearly as possible. We hope you'll find this manual easy to use. There will be times when you need to take this manual out of the glovebox. When you do, please be sure to return it when you are finished using it.



#### NOTE

After you've read this manual, it should be stored in the cab for convenient ref-

erence and remain with this truck when sold.

Your vehicle may not have all the features or options mentioned in this manual. Therefore, you should pay careful attention to the instructions that pertain to just your vehicle. In addition, if your vehicle is equipped with special equipment or options not discussed in this manual, consult your dealer or the manufacturer of the equipment. There are several tools built into this manual to help you find what you need quickly and easily; first is the Quick Table of Contents. Located at the front of the manual, this table lists the main subjects covered and gives section numbers where you can find these subjects. Use the Quick Table of Contents to find information on a large subject and then use the detailed table of contents found on the first page of each chapter. Cross-referenced citations also help you get the information you need. If some other part of the manual contains further information on the subject you are reading about, we'll indicate that in a cross-reference like this: (See [Safety Alerts](#) on page 5).

Finally, you'll find a helpful Subject Index. It's in the back of the manual and alphabetically lists the subjects covered. All information contained in this manual is based on the latest production information available at the time of publication. Kenworth Truck Company reserves the right to make changes at any time without notice.

### Safety Alerts

Read and follow all of the safety alerts contained in this manual. They are there for your protection and information. These alerts can help you avoid injury to yourself, your passengers, and help prevent costly damage to the vehicle. Safety alerts are highlighted by safety alert symbols and signal words such as "WARNING," "CAUTION," or "NOTE." DO NOT ignore any of these alerts.

### Warnings



The safety message following this symbol and signal word provides a warning against operating procedures which could cause death or injury. They could also cause

equipment or property damage. The alert will identify the hazard, how to avoid it, and the probable consequence of not avoiding the hazard.

Example:

 <b>WARNING</b>
<p>Hot engine oil can be dangerous. You could be burned. Let the engine oil cool down before changing it. Failure to comply may result in death, personal injury, equipment or property damage.</p>

**Cautions**



The safety message following this symbol and signal word provides a caution against operating procedures which could cause equipment or property damage. The alert will identify the hazard, how to avoid it, and the probable consequence of not avoiding the hazard.

Example:

 <b>CAUTION</b>
<p>Continuing to operate your vehicle with insufficient oil pressure will cause serious engine damage. Failure to comply may result in equipment or property damage.</p>

**Notes**



The message following this symbol and signal word provides important information that is not safety related but should be followed. The alert will highlight things that may not be obvious and is useful to your efficient operation of the vehicle.

Example:

 <b>NOTE</b>
<p>Pumping the accelerator will not assist in starting the engine.</p>

**Forward**

This manual contains information for the correct operation and maintenance of your PACCAR engine. Read and follow all safety instructions. Refer to the WARNING in the [General Safety Instructions](#) on page 7. Keep this manual with the equipment. If the equipment is traded or sold, give the manual to the new owner.

The information, specifications, and recommended maintenance guidelines in this manual are based on information in effect at the time of printing. PACCAR reserves the right to make changes at any time without obligation. If you find differences between your engine and the information in this manual, contact your local PACCAR Authorized Repair Location or write to:

PACCAR c/o PACCAR Engines

PO Box 1518 Bellevue, WA 98009

The latest technology and the highest quality components were used to produce this engine. When replacement parts are needed, we recommend using only genuine parts from PACCAR.



**NOTE**

Warranty information including the EPA and California Emission Warranty is located in the section entitled "Engine Warranty." Make sure you are familiar with the warranty or warranties applicable to your engine.

**Illustrations**

Some of the illustrations throughout this manual are generic and will not look exactly like the engine or parts used in your application. The illustrations can contain symbols to indicate an action required and/or an acceptable or unacceptable condition.

The illustrations are intended to show repair or replacement procedures. The procedure will be the same for all applications, although the illustrations may differ.

**General Safety Instructions****WARNING**

Improper practices, carelessness, or ignoring any warnings may cause property damage, personal injury, or death.

**WARNING**

Manually rotating the crankshaft requires a trained technician and specialty tools. DO NOT pull or pry on the fan in an attempt to rotate the crankshaft. Applying force to the fan can damage the fan blades or cause premature fan failure. Failure to comply with the approved procedure may result in property damage, personal injury, or death.

Before performing any repair, read and understand all of the safety precautions and warnings. The following is a list of general safety precautions that must be followed to provide personal safety. Failure to follow these instructions may cause death or injury. Special safety precautions

are included in the procedures when they apply.

Keep in mind that even a well maintained vehicle must be operated within the range of its mechanical capabilities and the limits of its load ratings. See the Weight Ratings label on the driver's door edge.

Every new vehicle is designed to conform to all Federal Motor Vehicle Safety Standards applicable at the time of manufacture. Even with these safety features, continued safe and reliable operation depends greatly upon regular vehicle maintenance. Follow the maintenance recommendations found in the Preventive Maintenance section. This will help preserve your investment. Make sure your vehicle is in top working condition before heading out on the road, it is the responsible driver's duty to do so. Inspect the vehicle according to the Driver's Check List.

- Work areas should be dry, well lit, well ventilated, free from clutter, loose tools, parts, ignition sources and hazardous substances.
- Wear protective glasses and protective shoes when working.
- DO NOT wear loose-fitting or torn clothing. Tie back and/or tuck in

long hair. Remove all jewelry when working.

- Before beginning any repair, disconnect the battery (negative [-] cable) and discharge any capacitors.
- Put a “DO NOT OPERATE” tag in the operator’s compartment or on the controls.
- Allow the engine to cool before slowly loosening the coolant fill cap to relieve the pressure from the cooling system.



### WARNING

Removing the fill cap on a hot engine can cause scalding coolant to spray out and burn you badly. If the engine has been in operation within the previous 30 minutes, be very careful in removing the fill cap. Protect face, hands, and arms against escaping fluid and steam by covering the cap with a large, thick rag. DO NOT try to remove it until the surge tank cools down or if you see any steam or coolant escaping. Always remove the cap very slowly and carefully. Be ready to back

off if any steam or coolant begins to escape. Failure to comply may result in death, personal injury, equipment or property damage.

- Always use wheel chocks or proper jack stands to support the vehicle or vehicle components before performing any service work. DO NOT work on anything that is supported only by lifting jacks or a hoist. Before resting a vehicle on jack stands, be sure the stands are rated for the load you will be placing on them.
- Before removing or disconnecting any lines, fittings, or related items, relieve all pressure in the air, oil, fuel, and cooling systems. Remain alert for possible pressure when disconnecting any device from a system that contains pressure. High pressure oil or fuel can cause death or personal injury.
- Always wear protective clothing when working on any refrigerant lines and make sure that the workplace is well ventilated. Inhalation of fumes can cause death or personal injury. To protect

the environment, liquid refrigerant systems must be properly emptied and filled using equipment that prevents the release of refrigerant gas. Federal law requires capturing and recycling refrigerant.

- When moving or lifting any heavy equipment or parts, make sure to use proper techniques and assistance. Ensure all lifting devices such as chains, hooks, or slings are in good condition and are of the correct load capacity. Make sure all lifting devices are positioned correctly.
- Corrosion inhibitors and lubricating oils may contain alkali. DO NOT get the substance in eyes and avoid prolonged or repeated contact with skin. DO NOT swallow. If ingested, seek immediate medical attention. DO NOT induce vomiting. In case of contact, immediately wash skin with soap and water. In case of harmful contact, immediately contact a physician. Always keep any chemicals OUT OF REACH OF CHILDREN.
- Naphtha and Methyl Ethyl Ketone (MEK) are flammable materials and

must be used with caution. Follow the manufacturer's instructions to ensure safety when using these materials. Always keep any chemicals OUT OF REACH OF CHILDREN.

- When working on the vehicle, be alert for hot parts on systems that have just been turned off, exhaust gas flow, and hot fluids in lines, tubes, and compartments. Contact with any hot surface may cause burns.
- Always use tools that are in good condition. Make sure you have the proper understanding of how to use the tools before performing any service work. Use only genuine replacement parts from PACCAR.
- Always use the same fastener part number (or equivalent) when replacing items. DO NOT use a fastener of lesser quality if replacements are necessary. (e.g., DO NOT replace a SAE 10.9 grade with 8.8 grade fastener.)
- Always torque fasteners and fuel connections to the required specifications. Overtightening or undertightening can allow leakage.
- Close the manual fuel valves prior to performing maintenance and repairs, and when storing the vehicle inside.
- DO NOT perform any repair when impaired, tired, fatigued, or after consuming alcohol or drugs that can impair your functioning.
- Some state and federal agencies in the United States of America have determined that used engine oil can be carcinogenic and can cause reproductive toxicity. Avoid inhalation of vapors, ingestion, and prolonged contact with used engine oil.
- DO NOT connect the jump starting or battery charging cables to any ignition or governor control wiring. This can cause electrical damage to the ignition or governor.
- Coolant is toxic. If not reused, dispose of coolant in accordance with local environmental regulations.



### CAUTION

Corrosive chemicals can damage the engine. DO NOT use corrosive chemicals on the engine. Failure to comply may result in equipment or property damage.

### California Proposition 65 Warning

- Diesel engine exhaust and some of its constituents are known to the State of California to cause cancer, birth defects, and other reproductive harm.
- The catalyst substrate located in the Diesel Particulate Filter (DPF) contains vanadium pentoxide, which has been determined by the State of California to cause cancer. Always wear protective clothing and eye protection when handling the catalyst assembly. Dispose of the catalyst in accordance with local regulations. If catalyst material gets into the eyes, immediately flood eyes with water for a minimum of 15 minutes. Avoid prolonged contact with skin. In case of contact, immediately wash

skin with soap and water. In case of harmful contact, immediately contact a physician.

- Other chemicals in this vehicle are also known to the State of California to cause cancer, birth defects or other reproductive harm.
- Battery posts, terminals, and related accessories contain lead and lead compounds, chemicals known to the State of California to cause cancer and reproductive harm. Wash hands after handling.

## Emergency - What To Do If

### Roadside Assistance

Call toll-free to talk to someone at the PACCAR Customer Center:

- Kenworth customers call: **1-800-KW-Assist (1-800-592-7747)** | Peterbilt customers call: **1-800-4Peterbilt (800-473-8372)**
- Open 24-7-365 days a year.
- They can help you get roadside assistance.
- They have a custom mapping system which locates authorized

PACCAR engine dealers and Independent Service Providers (ISPs) near you and lists types of services offered, hours of operation and contact information.

- They can assist with jump and pull starts, tires, trailers, fines and permits, chains, towing, hazardous clean-up, out of fuel (roadside), mechanical repairs and preventive maintenance services.
- They have multilingual agents and access to a translation service to ensure quality assistance for customers in any language.
- They can't answer your warranty questions, but can get you in contact with an authorized dealer who can.
- The PACCAR Customer Center service is FREE.

### Stop Engine Lamp

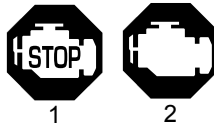

The stop engine warning lamp will illuminate, and an audible tone will sound, when a major engine problem exists. Your vehicle will be equipped with one of the indicators above, 1 or 2, depending on the engine model.



### WARNING

If the Stop Engine warning lamp illuminates, it means you have a serious engine system problem. This should be considered an emergency. You should stop the vehicle as safely as possible and turn OFF the ignition. The vehicle must be serviced and the problem corrected before driving again. Failure to comply may result in death, personal injury, equipment or property damage.

For engines with the engine-protection shutdown feature enabled, the stop engine lamp will begin to flash 30 seconds before the engine automatically shuts down. The warning lamp alerts the operator to the impending shutdown.

The lamp will also illuminate when the DEF tank is almost empty or the soot level in the DPF is at full capacity. At this level warning, regeneration cannot be performed and engine power will be derated.

Engine may automatically shut down if the check engine lamp and stop engine lamp are illuminated and the operator does not correct the condition.

### Engine Oil Pressure Lamp Turns On

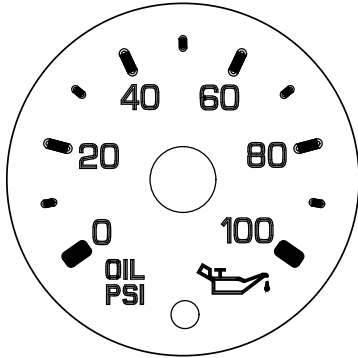

It is important to maintain oil pressure within acceptable limits. If oil pressure drops below the minimum psi a red warning lamp on the oil pressure gauge and the Stop Engine Lamp will come ON.



### CAUTION

Continuing to operate your vehicle with insufficient oil pressure will cause serious engine damage. Failure to comply may result in equipment or property damage.

- If the oil pressure fails to rise within 10 seconds after the engine starts, stop the engine and determine the cause.
- See Engine Oil Specification for the correct oil pressure ranges for your vehicle's engine.
- If the oil pressure suddenly drops, or the audible alarm and engine oil pressure warning light come on while driving, do the following:
  1. Slow down carefully.
  2. Move a safe distance off the road and stop.
  3. Place the transmission in neutral (N) and set the parking brake. (See Parking Brake Valve and Operating the Transmission in your vehicle Operator's Manual, for transmission shifting and parking brake information.)

4. Turn OFF the engine.
5. Turn ON the emergency flasher and use other warning devices to alert other motorists.
6. Wait a 15-20 minutes to allow oil to drain into the engine oil pan, and then check the oil level. See Engine Oil Level.
7. Add oil if necessary. If the problem persists, contact an authorized PACCAR engine dealer as soon as possible.

### Check Engine Lamp Turns On



Or



**Check Engine Lamp** - Turns on when a problem exists, but the vehicle can still be safely driven. Vehicle should be serviced to correct the problem but the situation should not be considered an emergency. The lamp will also illuminate when a DPF regeneration or addition of diesel exhaust

1

fluid (DEF) is required. Another function of the check engine lamp is to warn the operator of an impending idle shutdown. When the idle shutdown timer is 30 seconds from expiring, the ECM begins flashing the check engine warning lamp once per second. When the timer expires, the ECM will turn off the warning lamp and shut down the engine.

### Engine is Overheating



### CAUTION

The cooling system may overheat if the engine coolant is at the minimum level. A sudden loss of coolant, caused by a split hose or broken hose clamp could also lead to an overheat condition. Always inspect to ensure hoses and clamps are not cracked, worn, or loose. Failure to comply may result in equipment or property damage.



### NOTE

The system may also temporarily overheat during severe operating conditions such as:

- Climbing a hill on a hot day
- Stopping after high-speed/high-load driving
- Debris blocking air flow through the cooling module (radiator)

If the engine coolant temperature warning lamp comes on and the audible alarm sounds showing an overheat condition, or if you have any other reason to suspect the engine may be overheating, DO NOT TURN OFF THE ENGINE unless a low water warning device indicates a loss of coolant.

Follow these steps if the engine coolant temperature is rising, or the temperature is already above normal, and there are no other warning alarms displayed in the instrument cluster.



### NOTE

The instrument cluster gauges may appear, if hidden from view, change brightness and change color to bring attention to a particular system.

1. Reduce engine speed, or stop. When stopped, place the transmission in neutral (N) and set the parking brake. Keep the engine running.

**WARNING**

To reduce the chance of personal injury, vehicle damage, and/or death from overheated engines, which can result in a fire, never leave the engine idling without an alert driver present. If the engine does overheat, as indicated by the engine coolant temperature lamp, immediate action is required to correct the condition. Continued unattended operation of the engine, even for a short time, may result in serious engine damage or a fire. Failure to comply may result in death, personal injury, equipment or property damage.

**WARNING**

Removing the fill cap on a hot engine can cause scalding coolant to spray out and burn you badly. If the engine has been in operation within the previous 30 minutes, be very careful in removing the fill cap. Protect face, hands, and arms against escaping fluid and steam by covering the cap with a large, thick rag. DO NOT try to remove it until the surge tank cools down

or if you see any steam or coolant escaping. Always remove the cap very slowly and carefully. Be ready to back off if any steam or coolant begins to escape. Failure to comply may result in death, personal injury, equipment or property damage.

**NOTE**

Keep the engine running at idle speed unless a warning icon turns on that requires the engine to be shut off.

2. Check to ensure the Oil Pressure Gauge reads normal.
3. Make sure the engine fan is turning by switching the **Engine Fan Switch** from AUTO to MAN (Manual).
4. Idle the engine to see if this reduces the coolant temperature. If the temperature does not begin to drop, shut off the engine and contact your nearest authorized dealer.
5. If the temperature begins to return to normal, allow the engine to idle 3 to 5 minutes before shutting it off.

- This allows the engine to cool gradually and uniformly.
6. If overheating came from severe operating conditions, the temperature should have cooled by this time. If it has not, stop the engine and let it cool before checking to see if the coolant is low.
  7. Be sure the vehicle is parked on level ground or the readings may be incorrect. Check the coolant level at the coolant surge tank.

Check the coolant level after each trip when the engine has cooled. The coolant level should be visible within the surge tank. Add coolant if necessary.

## Operating Instructions

### Engine Warning Lamps

The following engine warning lamps section covers only the lamps controlled by the engine's Electronic Control Module (ECM). Please refer to the vehicle "Operator's Manual" and "Engine Aftertreatment Systems" manuals for additional warning lamp information.



**CAUTION**

The installation of electronic devices to the On Board Diagnostics (OBD) connector, the vehicle Controller Area Network (CAN), or their associated wiring is not permitted. Doing so can adversely affect vehicle performance and/or cause fault codes to be recorded. The OBD connector is provided for temporary connection of service tools and for diagnostic purposes only.



**WARNING**

If the Stop Engine warning lamp illuminates, it means you have a serious engine system problem. This should be considered an emergency. You should stop the vehicle as safely as possible and turn OFF the ignition. The vehicle must be serviced and the problem corrected before driving again. Failure to comply may result in death, personal injury, equipment or property damage.

**Stop Engine Lamp**

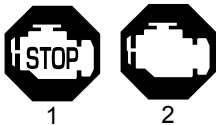

1

2

The stop engine warning lamp will illuminate, and an audible tone will sound, when a major engine problem exists. Your vehicle will be equipped with one of the indicators above, 1 or 2, depending on the engine model.

For engines with the engine-protection shutdown feature enabled, the stop engine lamp will begin to flash 30 seconds before the engine automatically shuts down. The warning lamp alerts the operator to the impending shutdown.

The lamp will also illuminate when the DEF tank is almost empty or the soot level in the DPF is at full capacity. At this level warning, regeneration cannot be performed and engine power will be derated.

Engine may automatically shut down if the check engine lamp and stop engine lamp are illuminated and the operator does not correct the condition.

**Engine, Check Engine**



Or



Illuminates when a non emissions related problem exists, but the vehicle can still be safely driven. Vehicle should be serviced to correct the problem but the situation should not be considered an emergency.

**Malfunction Indicator Lamp**

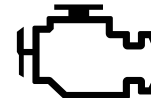

Illuminates when an engine emissions failure has occurred. The vehicle can be safely driven but should be serviced to correct the problem. The situation should not be considered an emergency. In some cases, the Malfunction Indicator Lamp (MIL) will activate in conjunction with the High Exhaust System Temperature



(HEST), Diesel Particulate Filter (DPF) and Diesel Exhaust Fluid (DEF) warning lamps.



#### NOTE

The malfunction indicator lamp (MIL) will illuminate if the on-board diagnostics (OBD) system detects a possible emissions system failure. The vehicle should be brought in for service at the next opportunity to ensure the condition is corrected.

### Water-In-Fuel (WIF) Lamp



If the WIF notification is present, manually drain the water at the engine mounted primary fuel filter as soon as possible. Failure to drain the water and then continuing to operate the engine could cause the water to be sent back to the fuel

tank. If this happens, draining the fuel tank may become necessary. This procedure can be avoided if the operator or technician drains the water from the fuel filter module frequently at the primary fuel filter.

### Diesel Particulate Filter (DPF) Warning Light

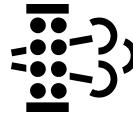

This icon and related message will appear when the DPF needs to be regenerated and then also during the regeneration cycle. This may also appear if the system is attempting to automatically regenerate while the vehicle is in Power Take Off operation mode.

Engine aftertreatment system includes a diesel particulate filter and DPF warning light.

### High Exhaust System Temperature (HEST) Warning Lamp



Keep vehicle a safe distance from combustible items.



#### WARNING

Temperature of the tail pipe, exhaust pipe, the diesel particulate filter (DPF)/selective catalytic reduction (SCR) device and surrounding components including enclosures and steps, will be elevated during and shortly after a regeneration event or normal vehicle operation when engine is under high or heavy loading.

If the High Exhaust System Temperature (HEST) warning lamp is on:

- Do not park in an area of combustible vapors or materials. You must keep combustibles at least 5 ft. (1.5 m) away from the exhaust (outlet) stream (as it exits the tail pipe) while the HEST lamp

is illuminated. Always park your vehicle outside. Failure to do so could ignite an explosion or harm bystanders which could result in serious injury.

- Do not park in an area where people are close by. You must keep combustibles at least 5 ft. (1.5 m) away from the exhaust outlet while the HEST lamp is illuminated. Failure to do so could result in serious injury.
- Do not approach the exhaust system or surrounding areas without allowing adequate time for the system to cool down. Failure to do so could result in serious burns to the skin.

### Diesel Exhaust Fluid (DEF) Lamp

The engine aftertreatment system includes a diesel exhaust fluid (DEF) warning lamp on the DEF gauge and additional warning lamps or popup messages in the instrument cluster. Refer to the operator manual for more details.

The engine aftertreatment system includes diesel exhaust fluid (DEF) warning lamps or popup messages in the instrument

cluster. Refer to the operator manual for more details.

#### DEF Warning Lamp in Instrument Cluster



The system will alert the operator when the fluid in the DEF tank reaches a low level. Refer to the operator manual for more details. If the lamp illuminates but the level is full, seek service immediately for DEF fluid quality or DEF equipment repair.

### Engine Braking System

An engine compression brake is standard on the MX-13 engines. Optionally, this engine may be equipped with an exhaust brake. When activated, these devices supplement the service brakes by creating a braking effect on the drive wheels, helping keep your vehicle's service brakes from overheating and/or from additional wear and tear. The engine compression brake or exhaust brake is not an emergency brake nor intended to replace the service brakes.



#### WARNING

DO NOT operate the engine compression brake or exhaust brake when driving/operating your vehicle bobtail or with a loaded or unloaded trailer on road surfaces with poor traction (wet, icy, or snow covered roads) or in heavy traffic. There may not be enough weight on the rear axle to provide traction. Braking caused by the normal operation of the engine compression brake or exhaust brake could cause you to lose control of the vehicle, resulting in an accident. Make sure the engine compression brake or exhaust brake is switched "OFF" when driving bobtail or with an unloaded trailer. Failure to comply may result in death, personal injury, equipment, or property damage.

**WARNING**

The service brakes must be used in an emergency. The engine compression brake or exhaust brake alone might not stop the vehicle fast enough to prevent an accident. The engine compression brake or exhaust brake is NOT intended as the primary brake for the vehicle, nor is it an emergency brake. The engine compression brake or exhaust brake only helps the service brakes by using engine back pressure to slow the drivetrain. Use the service brakes for quick stops. You could be seriously injured if you relied only on the engine compression brake or exhaust brake to stop the vehicle in an emergency. Failure to comply may result in death, personal injury, equipment or property damage.

**CAUTION**

DO NOT operate the engine compression brake or exhaust brake until the engine oil temperature is above 86°F (30°C). Operation below 86°F (30°C)

could cause severe damage to the engine. Idle the engine four minutes at approximately 1,000 rpm to warm the engine before activating the engine brakes.

**NOTE**

If your vehicle is equipped with anti-lock brakes (ABS), operation of the engine compression brake or exhaust brake (if turned ON) may be interrupted if the ABS system detects wheel-slip due to operation on slippery surfaces.

Ideally (on normal road surfaces), you should slow your vehicle with the engine compression brake or exhaust brake (where permitted by law) and use the service brakes only for stopping completely. Operating this way will greatly prolong the life of the service brakes.

**Engine Compression Brake**

With the engine compression brake switch ON, the brake automatically creates its braking effect when you remove your foot from the accelerator pedal.

The brake switch is located on the accessory dash panel. It controls whether the brake is ON (ready to slow the vehicle down) or OFF (no braking action).

1. Do not use the engine compression brake to slow the vehicle down when you are bobtailing or pulling an empty trailer.
2. Make sure the brake is OFF before starting the engine.
3. After the engine is started, warmed up and you are ready to get under way, turn the engine compression brake switch ON for added braking effect.

**NOTE**

If your vehicle is equipped with the Eaton Vorad® system, operation of the compression brake may be automatically activated.

**Engine Compression Brake Controls**

There are two switches on the dash panel that control the engine compression brake. A master switch turns the system ON or OFF. A second switch, located next to the master switch, controls the braking effect.

This switch allows you to choose progressively stronger braking to slow the vehicle down.

Engine compression brake controls include:

- ON/OFF switch
- Three-position selector switch
- Clutch switch
- Throttle sensor
- Service brake pressure switch
- Eaton Vorad® Anti-Lock Braking System

Engaging conditions for the engine compression brake:

- Engine speed must be above 1,000 rpm.
- Coolant temperature must be above 59°F (15°C).

Deactivation conditions for the engine compression brake:

- Accelerator pedal is depressed.
- Clutch pedal is depressed.
- Engine speed falls below 800 rpm.
- ABS control is active.
- ECM recognizes a system problem.



**CAUTION**

Operating the engine with a compression brake that will not automatically deactivate (i.e. when the dash switch is OFF, clutch pedal is depressed or throttle is applied) will cause severe internal engine damage. DO NOT operate the engine if the compression brake will not deactivate. Failure to comply may result in equipment or property damage.

**Engine Compression Brake Level Switch Operation**

For the three-position engine compression brake level switch, there will be 100 percent engine braking when the switch is in the up (HIGH) position. In the middle (MEDIUM) position, there will be 66 percent engine braking. In the down (LOW) position there will be 33 percent engine braking.

With the engine compression brake switch ON, the engine compression brake will be engaged when the service brake is applied. If the cruise control is operated in conjunction with the engine compression

brake, the engine compression brake will engage to maintain the cruise set speed.

Engine Compression Brake on/off

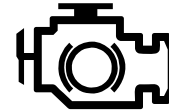

Engine Compression Brake setting

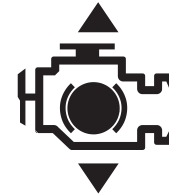

**Driving**

Correct care of your engine will result in longer life, better performance, and more economical operation.

Follow the daily maintenance checks listed in [Engine Maintenance](#) on page 32.

Check the engine oil pressure and engine coolant gauges, warning lamps, and other gauges daily to make sure they are operational. Normally each gauge will

make a full sweep when ignition key is cycled ON to indicate that the gauge is operating correctly.

Generic gauges. Your gauges may differ.

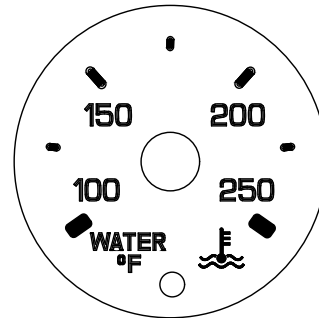
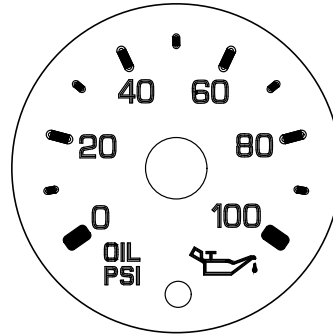

### NOTE

If the engine is running, increase engine speed (rpm) or operate the vehicle until the low oil pressure warning lamp turns off.

### CAUTION

Engaging the starter motor for more than 30 seconds in any five minute period may cause it to overheat and can damage the starter.

- If starter is engaged continuously for 30 seconds, you must wait five minutes before trying to start the engine to allow the starter motor to cool down.

With the key in the ON position, the engine warning lamps will come on momentarily and then go out. The engine warning lamps include:

**Engine Operation Symbols**



Or



Check engine lamp; yellow in color.



Stop engine lamp; red in color.

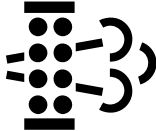

Diesel particulate filter (DPF) status indicator; yellow in color.



High exhaust system temperature (HEST); amber in color.

**Combustible Vapors**

**WARNING**

Combustible vapors near the air intake system could be ingested into the engine, causing the engine to suddenly accelerate and overspeed. This condition could result in the operator losing control of the vehicle if an unexpected increase in engine rpm occurs. Combustible vapors could also cause a fire. DO NOT operate your vehicle in an area where combustible chemicals or vapors may be present. Failure to comply may result in death, personal injury, equipment or property damage.

**NOTE**

IT IS THE RESPONSIBILITY OF THE OWNER AND OPERATOR TO OPERATE THE VEHICLE IN A SAFE ENVIRONMENT.

**Normal Starting Procedure**

Follow this engine starting procedure when the outside temperature is above 50°F (10°C).

1. Ensure the parking brake is set ON and the transmission shift lever is in neutral. For automatic transmissions, be sure the shift lever is in the neutral position (N). For automatic transmissions that have park (P) position, place the shift lever in park.

**NOTE**

If outside temperature is below 50°F (10°C) go to the Cold Weather Starting Procedure. Start at step 2 and follow the directions until it directs you back to step 2 of this procedure.

2. With the accelerator pedal in the idle position, turn the ignition key to the START position to start the engine.
3. If the engine does not start after 10 seconds, release the key. Wait an additional 10 seconds to allow the starter motor to cool, then try starting the engine again.
4. Once the engine has started, wait for the oil pressure to rise, and the low oil pressure warning lamp to turn off, before increasing rpm.

If the engine does not start, or runs erratically, see Priming the Fuel System.

### Cold Weather Starting

Follow this engine starting procedure when the outside temperature is below 50°F (10°C).



#### CAUTION

To reduce the possibility of damage to the lubricating oil pan, due to the materials used in the manufacture of the lubricating oil pan, under no circumstances should an external heat

source be applied directly or indirectly to the lubricating oil pan.

1. If you have not already, begin by following the [Normal Starting Procedure](#) on page 20 until it directs you back to step 2 in this cold weather procedure

Refer to the vehicle operator's manual instructions for any additional cold weather starting procedures.

2. Allow the 12 volt fuel module pre-heater to heat the fuel. Leave the key in the accessory position, without engaging the starter until the Wait-To-Start lamp goes out.

During cold weather, the use of winter fuel blends can significantly improve the ease of starting performance, and overall dependability of your vehicle. Winter fuel blends are designed to reduce wax gelling in the fuel filter and lines.

If Starting a cold engine, remember to slowly increase the engine speed. This provides adequate lubrication to the bearings and gives ample time to allow the oil pressure to stabilize. Also, if starting a cold engine, slowly increase the engine speed. This provides adequate lubrication to the bearings and gives ample time to

allow the oil pressure to stabilize. Also, for coolant temperatures below 150°F (70°C), use a low gear and drive at moderate engine speed until the engine coolant has reached operating temperature. Do not let the engine idle longer than necessary. If the vehicle cannot be driven, an elevated idle speed may be used instead to warm the engine.

3. Return to step 2 in the Normal Starting Procedure



#### CAUTION

The use of starting aids, such as ether, may result in damage to the engine and engine aftertreatment system.

### Starting Procedure After Extended Shutdown or Oil Change

After extended shutdown or an oil change follow the [Normal Starting Procedure](#) on page 20.

### Operating the Engine

Monitor the oil pressure and coolant temperature gauges frequently. Refer to [Engine Oil Capacities and Pressures](#) on page 57 and [Engine Coolant Specifications](#) on page 62 for

1

recommended operating pressures and temperatures. Shut off the engine if any pressure or temperature does NOT meet the specifications.

### Manual Transmission Variable Idle Control



#### NOTE

If your truck is equipped with a manual transmission, your engine idle RPM may vary under certain conditions. The engine control module will control the RPM based on various inputs such as vehicle weight, rear axle ratio, road grade and altitude. When starting from a stop, depending on these conditions, the engine RPM may increase to compensate for load in order to ensure a smooth transition into motion.

### Engine Operating Range



#### CAUTION

Operating the engine at full throttle below peak torque will shorten engine life

to overhaul, can cause serious engine damage, and is considered engine abuse. DO NOT operate the engine at full throttle operation below peak torque rpm for more than 30 seconds. Failure to comply may result in equipment or property damage.

PACCAR engines are designed to operate at full throttle under momentary conditions down to peak torque engine speed. This is consistent with recommended operating practices.



#### CAUTION

Operating the engine beyond the maximum engine speed can cause severe engine damage. Use proper operating techniques for the vehicle to prevent engine overspeed. See Engine Specifications for maximum engine speed. Failure to comply may result in equipment or property damage.

### Extended Idling



#### CAUTION

Prolonged periods of idling can result in lower than optimal engine/transmission operating temperatures which could cause increased rates of wear. An idle shutdown feature (available on PACCAR engines) can be programmed to shut the engine down after a period of low idle operation with no driver activity. A flashing warning lamp will inform the driver of an impending shutdown. Failure to comply may result in equipment or property damage.



#### CAUTION

If the truck is equipped with power take-off (PTO) equipment, the engine shutdown system can be deactivated when the PTO is operational; however, engine idle periods should not exceed five minutes whenever possible. Failure to comply may result in equipment or property damage.



Long periods of idle-time (3 hours or more) may accelerate the build-up of soot in the diesel particulate filter (DPF), especially in cold weather. The system will illuminate the DPF indicator and a message to indicate that the DPF requires regeneration. Refer to the operator manual for more details. This is not a problem with the vehicle; however, it indicates that the driver needs to start a parked DPF regeneration to prevent equipment damage caused by soot build up. If the DPF lamp turns ON and the driver is prompted to through driver notifications, perform a parked DPF Regeneration.



### CAUTION

If you ignore the warning lamp and do not initiate regeneration at the soonest, safest possible time, the DPF will become increasingly clogged with soot and can lead to severe engine derate. Failure to comply may result in equipment or property damage.

Extended engine idling may also increase hydrocarbon deposits and moisture in the DPF. The engine will increase rpm automatically, regardless if the DPF lamp is

on or off, to remove these hydrocarbon deposits and moisture. The engine speed will remain elevated for 20-60 minutes. If necessary, the rpm may be lowered by briefly depressing the throttle, clutch, or brake pedal. If the driver cancels the automatic cycle using the pedals, the system will restart the cycle 10 minutes later with increased rpm until all of the deposits are removed from the DPF. If the vehicle cannot perform an automatic cycle, the driver may be prompted with message to regenerate the DPF with a "Do Not Drive" message. The driver must complete a regeneration before driving. If the "Do Not Drive" message is ignored and a DPF regeneration is not fully completed before driving, there is a high possibility of equipment damage.

If an engine must idle for an extended period of time, idle the engine at the lowest rpm that maintains the engine coolant at 150°F (70°C), or above. Following these guidelines will help reduce engine wear during idling and the frequency of DPF regenerations.

## Engine Shutdown



### NOTE

DO NOT shut off the engine immediately. A hot engine stores a great amount of heat and it does not cool down immediately after it is shut off. Always cool the engine down before shutting it off. You will greatly increase its service life.

Idle the engine at 1,000 rpm for four minutes. Then low idle for 30 seconds before shutdown. This will allow circulating coolant and lubricating oil to carry heat away from the cylinder head, valves, pistons, cylinder liners, turbocharger, and bearings. This way you can prevent engine damage that may result from uneven cooling.

Turn the ignition switch to the OFF position. If the engine does **not** shut down, contact your dealer.

## Electromagnetic Interference

If not installed correctly, some vehicle accessories (CB radios, mobile transmitters, etc.) can generate and use radio frequency energy that may cause electromagnetic interference (EMI)

between the accessory and the electronically controlled fuel system. Under these conditions, PACCAR is not liable for any performance problems with either the fuel system or the accessory. EMI is not considered by PACCAR to be an engine failure and therefore is not warrantable.

### System EMI Susceptibility

PACCAR products are designed and tested for minimum sensitivity to incoming electromagnetic energy. The fuel system EMI susceptibility has been designed with a high tolerance against EMI and in most normal circumstances, if not all, electromagnetic energy-emitting devices that meet the Federal Communications Commission legal requirements should cause no interference.

### System EMI Radiation Levels

Electronic components are required to pass various PACCAR and industry EMI specifications. Our testing has shown that when the engine is properly installed and maintained, it will not interfere with properly installed on-board communication equipment.

If any interference condition is noticed, follow these suggestions to reduce the amount of EMI:

1. Locate the accessory receiving antenna further away.
2. Check with the accessory supplier representative in your area to:
  - Accurately calibrate the accessory for proper frequency, power output, and sensitivity.
  - Determine the optimum antenna location by obtaining antenna reflective energy data measurements.
  - Ensure that the optimum antenna type and mounting arrangement is being used.
  - Ensure the accessory equipment is properly constructed for maximum filtering to reject incoming electromagnetic noise.

roads or gravel). Retarders can cause the wheels to skid on a slippery surface. You could lose control of the vehicle and/or jackknife if the wheels begin to skid, resulting in an accident. Failure to comply may result in death, personal injury, equipment or property damage.

### Operating on Level and Dry Pavement



#### WARNING

DO NOT use the engine compression brake or exhaust brake when operating on road surfaces with poor traction (such as wet, icy, or snow covered

**WARNING**

DO NOT operate the engine compression brake or exhaust brake when driving/operating your vehicle bobtail or with a loaded or unloaded trailer on road surfaces with poor traction (wet, icy, or snow covered roads) or in heavy traffic. There may not be enough weight on the rear axle to provide traction. Braking caused by the normal operation of the engine compression brake or exhaust brake could cause you to lose control of the vehicle, resulting in an accident. Make sure the engine compression brake or exhaust brake is switched "OFF" when driving bobtail or with an unloaded trailer. Failure to comply may result in death, personal injury, equipment, or property damage.

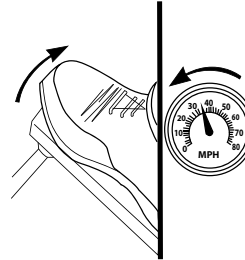
**Remove Foot from Accelerator**

To reduce vehicle speed, put the engine brake or exhaust brake ON/OFF switch in the "ON" position. Remove your foot from the accelerator pedal and clutch pedal. The engine brake or exhaust brake will immediately begin to operate, slowing the vehicle.

For operation on dry and relatively flat surfaces, when greater braking power is not required, put the two-position selector switch in the "LOW" position.

For operation on dry pavement when maximum braking power is required, put

the three-position selector switch in the "HI" position.

**Operating on Grades and Dry Pavement****WARNING**

The engine compression brake or exhaust brake is not intended as the primary brake for the vehicle, nor is it an emergency brake. The service brakes must be used in an emergency. Relying solely on the engine compression brake or exhaust brake to stop the vehicle in an emergency could cause an accident and lead to personal injury. The engine compression brake or exhaust brake only helps the service brakes by using pressure to slow the drive train. You must use the service brakes for quick or emergency stops. Failure to comply may result in death, personal injury, equipment or property damage.

"Control speed" is the speed at which the forces pushing a vehicle down a grade are equal to the forces holding it back.

**Do Not Exceed Governed Engine Speed**

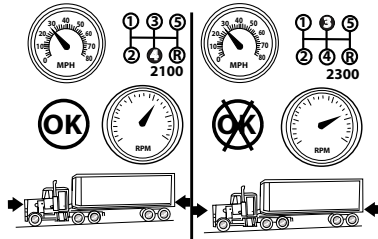

**WARNING**

DO NOT use the engine compression brake or exhaust brake when operating on road surfaces with poor traction (such as wet, icy, or snow covered roads, or gravel). The engine compression brake or exhaust brake can cause the wheels to skid on a slippery surface. You could lose control of the vehicle and/or jackknife if the wheels begin to skid, resulting in an accident. Failure to comply may result in death,

personal injury, equipment or property damage.



**CAUTION**

The engine ECM maintains a record of maximum rpm. Exceeding the maximum rpm will be considered driver abuse and will affect the engine warranty. See Engine Specifications.



**WARNING**

DO NOT operate the engine compression brake or exhaust brake when driving/operating your vehicle bobtail or with a loaded or unloaded trailer on road surfaces with poor traction (wet, icy, or snow covered roads) or in heavy traffic. There may not be enough weight on the rear axle to provide traction. Braking caused by the normal operation of the engine compression brake or exhaust brake could cause you to lose control of the vehicle, resulting in an accident. Make sure the engine compression brake or exhaust brake is switched "OFF" when

driving bobtail or with an unloaded trailer. Failure to comply may result in death, personal injury, equipment, or property damage.



**CAUTION**

Never exceed governed engine speed because engine damage can occur. Operating the engine beyond the governed speed causes additional strain on valve train and internal engine components. Operate the engine within governed engine speed.

**NOTE**

After you have determined what the safe speed is for your vehicle, operate the engine compression brake or exhaust brake with the transmission in the lowest gear that will not cause the engine speed to exceed the rated engine speed. The optimum braking power of the engine compression brake or exhaust brake is reached at rated engine speed. Correct gear selection, therefore, is critical.

The selector switch can be used to vary braking power as road conditions change. Vehicle service brakes must be used when additional braking power is required.

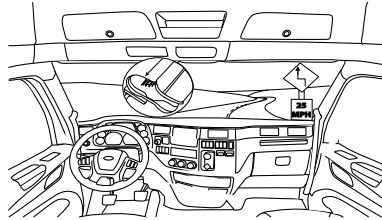
**Slow Down Around Curves**

The engine compression brake or exhaust brake is **NOT** intended as the primary brake for the vehicle, nor is it an emergency brake. The engine compression brake only helps the service brakes by using pressure to slow the drivetrain. Use the service brakes for quick stops.

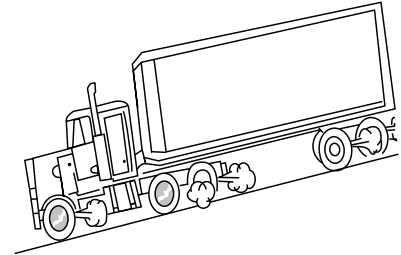
**Braking Truck on Grade****WARNING**

**DO NOT** drive with frequent or continuous use of the service brakes. This can overheat the brakes and result in excessive lining wear, increased stopping distances, possibly an accident and may lead to personal injury. Before descending a steep grade, shift to a lower gear, keep the vehicle speed low, and avoid continuous application to the brakes. Failure to comply may result in death, personal injury, equipment or property damage.



**NOTE**

The longer or steeper the hill, the more important it is to use your engine brake. Make maximum use of your engine brake by gearing down and letting the engine brake do the work.

**Shift to a Lower Gear on Grade**

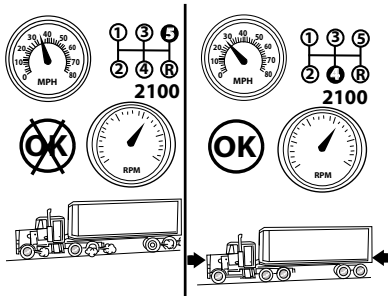

If frequent use of the vehicle service brakes is required, it is recommended that a slower control speed be used by selecting a lower transmission gear.

**Tips for Operation on Slick Roads**



**WARNING**

To reduce the possibility of personal injury or property damage, always allow for extra distance between your vehicle and other objects when using the service brakes or engine brakes on slick roads.

The operation of any vehicle is difficult to predict on slick roads. The first 10 to 15 minutes of rainfall are the most dangerous, as road dirt and oil mixed with rain create a very slippery surface.



**WARNING**

DO NOT use the vehicle's engine compression brake or exhaust brake in any situation that requires an immediate stop and/or in situations of poor traction (such as wet, icy, or snow covered roads). Trying to use the engine compression brake or exhaust brake instead of the service brakes may cause a loss of vehicle control, which

may result in an accident involving death or personal injury.

When driving on slick roads, start with the "ON/OFF" switch in the "OFF" position and the two-position selector switch in the "LOW" position. If your tractor is equipped with a twin-screw rear axle, position the power divider switch in the "unlocked" position. Remove your foot from the accelerator pedal to make sure the vehicle will maintain traction with the braking power of the engine alone. If the vehicle drive wheels begin to skid or if there is a fishtailing motion, DO NOT activate the engine compression brake or exhaust brake. If traction is maintained using the braking power of the engine alone and more braking power is required, switch the two-position selector switch to the "LOW" position and activate the engine compression brake or exhaust brake by switching the "ON/OFF" switch to the "ON" position. If the vehicle's drive wheels begin to skid or there is a fishtailing motion, switch the "ON/OFF" switch to the "OFF" position. If traction is maintained when the engine compression brake or exhaust brake is activated and more braking power is required, move the two-position selector switch to the "HI" position. Again, if the

vehicle has lost traction or if there is a fishtailing motion, switch the "ON/OFF" switch to the "OFF" position. DO NOT attempt to use the engine compression brake or exhaust brake in the "HI" position.

## Chapter 2 | MAINTENANCE

Maintenance Requirements.....	32
Preventative Maintenance Schedule Intervals.....	34
Normal Duty/Line Haul.....	34
Severe Duty/Vocational.....	44
Pick-up/Delivery/Refuse.....	49
Engine Specifications.....	54
Engine Lubricating Oil Recommendations and Specifications.....	56
Engine Oil Capacities and Pressures.....	57
Engine Lubrication and Filter Intervals.....	57
Cooling System Maintenance.....	59
Engine Coolant Specifications.....	62
Extended Life Coolant.....	63
Fuel Recommendations.....	63
Warranty and the Use of Renewable and Other Paraffinic Diesel Fuels.....	65
Warranty and the Use of Biodiesel Fuel.....	65
Recommendations to Avoid Fuel Gelling.....	66



Maintenance Procedures..... 66  
Engine Identification.....97

## Maintenance Requirements

### Engine Maintenance

PACCAR recommends that the engine be maintained according to the maintenance schedule in this section.

If the engine is operating in ambient temperatures below 0°F (-18°C) or above 100°F (38°C), perform maintenance at shorter intervals. Shorter maintenance intervals are also required if the engine is operated in a dusty environment or if frequent stops are made.

Some of these maintenance procedures require special tools or must be completed by qualified personnel. Contact your local PACCAR authorized repair location for detailed information.

If your engine is equipped with a component or accessory not manufactured by PACCAR Inc, refer to the component manufacturer's maintenance recommendations.



#### WARNING

Never idle your vehicle for prolonged periods of time if you sense that exhaust fumes are entering the cab. Investigate the cause of the fumes and correct it as soon as possible. If the vehicle must be driven under these conditions, drive only with the windows open. Failure to repair the source of the exhaust fumes may result in death, personal injury, equipment or property damage.



#### WARNING

Exhaust fumes from the engine contain carbon monoxide, a colorless and odorless gas. DO NOT breathe the engine exhaust gas. A poorly maintained, damaged or corroded exhaust system can allow carbon monoxide to enter the cab. Entry of carbon monoxide into the cab is also possible from other vehicles nearby. Failure to properly maintain your vehicle could cause carbon monoxide to enter the cab, resulting in death or personal injury.

### Cleaning the Engine

You must clean the undercarriage, engine compartment, and engine as needed, but at least annually. Cleaning removes road salt and debris that can be corrosive or otherwise harmful to the electrical system. Failure to properly clean the undercarriage of the truck can increase the risk of an electrical fire. When cleaning the engine, follow the instructions from the vehicle manufacturer's operator's manual and observe all environmental protection regulations.



#### CAUTION

Do not direct high pressure water onto electrical components, plug connectors, seals or flexible hoses on the engine. Failure to comply can accelerate corrosion and degrade electrical component which may cause a fire or equipment damage.

 **CAUTION**

Do not direct high pressure water onto seals or flexible hoses. Water may enter the part which will contaminate the system lubricants and fluids. To prevent damage to these components, keep a gentle flow of water moving at all times. Failure to comply may result in equipment damage.

**Daily or Refueling Maintenance Checks**

**Fuel Filter / Water Separator**

This procedure should be followed as part of daily and refueling maintenance checks.

1. Drain trapped water (if equipped). Refer to the Fuel Filter Water Draining Procedure.

**Air Intake Piping**

This procedure should be followed as part of daily and refueling maintenance checks.

1. Inspect hose/pipe condition – deterioration/signs of leaking.
2. Inspect hose clamps for tightness and pinching/cutting of hoses.

3. Inspect clearance to other components.
4. Check air restriction gauge.

**Aftertreatment Exhaust Piping**

This procedure should be followed as part of daily and refueling maintenance checks.

1. Inspect for cracks.
2. Inspect for clearance to other components (i.e. electrical harnesses, etc.).
3. Inspect hose/pipe condition – deterioration/signs of leaking.

**Cooling Fan**

This procedure should be followed as part of daily and refueling maintenance checks.

1. Inspect for cracks.
2. Inspect for clearance to other components.

**Coolant Level**

Replacement or top up coolant should have the same antifreeze concentration and corrosion inhibitor content as the original coolant in the cooling system. If operating in sub-freezing conditions, a 60/40 mix of antifreeze and distilled water may be substituted.

Always dilute antifreeze to the correct concentration based on freeze protection before adding it to the cooling system. Adding or using 100% antifreeze in a cooling system may result in cooling system plugging and overheating problems.

This procedure should be followed as part of daily and refueling maintenance checks. Perform the following steps to check the coolant level:

1. Check that vehicle is on a level surface.
2. Ensure engine has not been run for several hours.

 **CAUTION**

Due to thermal expansion the coolant level CANNOT be checked if the coolant is above ambient temperature or the engine has not completely cooled. The coolant level indicated on a warmed system will be inaccurate and can lead to low coolant conditions during cold-starts.

3. Check coolant level. It should be visible through the clear plastic surge tank.

4. Add coolant as necessary until proper level is reached; see special fill instruction if filling from empty.



**NOTE**

The pressure cap (on the rear-top of the surge tank) should NEVER be removed. The fill cap (on the ergonomic fill neck, not on the surge tank) is the correct fill point.

**Diesel Exhaust Fluid**

This procedure should be followed as part of daily and refueling maintenance checks.

1. Check level of diesel exhaust fluid.



**NOTE**

It is recommended to top up DEF when refueling. See Engine Aftertreatment Systems Operator's Manual for DEF information.

**Visual Inspection of Engine**

This procedure should be followed as part of daily and refueling maintenance checks.

1. Check for any signs of fluid leaks.
2. Ensure all access caps/covers are installed and tight.

**Bi-weekly Maintenance Check**

**Engine Oil Level Check**

This procedure should be followed as part of routine maintenance checks.

1. See [Engine Oil Level](#) on page 66

**Preventative Maintenance Schedule Intervals**

Perform maintenance at whichever interval occurs first. At Maintenance Schedule Intervals, perform all previous maintenance

checks that are due for scheduled maintenance.



**NOTE**

This maintenance schedule is for a normal duty cycle engine operation. Severe duty/vocational applications will need to adjust mileage, kilometer, hour, or time interval based on the Engine Lubrication and Filter Intervals.

**Normal Duty/Line Haul**

See manufacturer's recommended maintenance procedures. <sup>1</sup>

**Less than 20% Idle Time**

**Less than 20% Idle Time - 37,000 mi / 60,000 km / 1,125 hrs / 6 mo**

<sup>1</sup> Follow the manufacturers' recommended maintenance procedures for the starter, alternator, batteries, electrical components, exhaust brake, charge-air cooler, radiator, air compressor, air cleaner, refrigerant compressor, and fan clutch.

<b>Less than 20% Idle Time - 37,000 mi / 60,000 km / 1,125 hrs / 6 mo <sup>2</sup></b>
Air system and compressor <ul style="list-style-type: none"> <li>Refer to <a href="#">Air Compressor</a> on page 93 for maintenance instructions.</li> <li>Refer to <a href="#">Engine Air Filters</a> on page 93 for maintenance instructions.</li> </ul>
Charge Air System <ul style="list-style-type: none"> <li>Refer to <a href="#">Charge Air Piping</a> on page 93 for maintenance instructions.</li> <li>Refer to <a href="#">Charge Air Cooler</a> on page 93 for maintenance instructions.</li> </ul>
Charging/Cranking System <ul style="list-style-type: none"> <li>Refer to <a href="#">Electrical Harness / Cables</a> on page 95 for maintenance instructions.</li> </ul>
Cooling System <ul style="list-style-type: none"> <li>Refer to <a href="#">Coolant/Antifreeze Condition</a> on page 82 for maintenance instructions.</li> </ul>

**Less than 20% Idle Time - 75,000 mi / 120,000 km / 2,250 hrs / 12 mo (1 yr)**

<b>Less than 20% Idle Time - 75,000 mi / 120,000 km / 2,250 hrs / 12 mo (1 yr) <sup>3</sup></b>
Charging / Cranking System <ul style="list-style-type: none"> <li>Refer to <a href="#">Batteries, Cables, and Connections</a> on page 95 for maintenance instructions.</li> </ul>

<sup>2</sup> Ensure that all maintenance intervals leading up to this point are repeated during this interval prior to the completion of those listed here.

<sup>3</sup> Ensure that all maintenance intervals leading up to this point are repeated during this interval prior to the completion of those listed here.

**Less than 20% Idle Time - 75,000 mi / 120,000 km / 2,250 hrs / 12 mo (1 yr) <sup>3</sup>**

Drive Belts

- Refer to [Engine Belt Checks](#) on page 87 for maintenance instructions.
- Refer to [Fan Belt Tensioner \(If So Equipped\)](#) on page 87 for maintenance instructions.

Engine Lubrication

- Refer to [Engine Lubrication and Filter Intervals](#) on page 57 for maintenance instructions.

Fuel System

- Refer to [Fuel Filter](#) on page 76 - Replace<sup>4</sup>

**Less than 20% Idle Time - 150,000 mi / 240,000 km / 4,500 hrs / 24 mo (2 yrs)**

**Less than 20% Idle Time - 150,000 mi / 240,000 km / 4,500 hrs / 24 mo (2 yrs) <sup>5</sup>**

Cooling System

- Refer to [Radiator Hoses](#) on page 83 for maintenance instructions.

Crankshaft

- Refer to [Crankshaft - Vibration Damper](#) on page 96 for maintenance instructions.

<sup>3</sup> Ensure that all maintenance intervals leading up to this point are repeated during this interval prior to the completion of those listed here.

<sup>4</sup> Use of poor quality fuel may require more frequent fuel filter element service.

<sup>5</sup> Ensure that all maintenance intervals leading up to this point are repeated during this interval prior to the completion of those listed here.

<b>Less than 20% Idle Time - 150,000 mi / 240,000 km / 4,500 hrs / 24 mo (2 yrs) <sup>5</sup></b>
<p>Mounting Bolts</p> <ul style="list-style-type: none"> <li>Refer to <a href="#">Engine Mounting Bolts</a> on page 96 for maintenance instructions.</li> </ul>

**Less than 20% Idle Time - 300,000 mi / 480,000 km / 6,750 hrs / 36 mo (3 yrs)**

<b>Less than 20% Idle Time - 300,000 mi / 480,000 km / 6,750 hrs / 36 mo (3 yrs) <sup>6</sup></b>
<p>Aftertreatment System</p> <ul style="list-style-type: none"> <li>Refer to <a href="#">Diesel Particulate Filter (DPF) Service Strategy</a> on page 90 - Dry Cleaning Strategy.</li> <li>Refer to <a href="#">Diesel Exhaust Fluid (DEF) Filter</a> on page 91 for maintenance instructions.</li> </ul>
<p>Cooling System</p> <ul style="list-style-type: none"> <li>Refer to <a href="#">Replace Coolant Filter</a> on page 83 for maintenance instructions.</li> </ul>

**Less than 20% Idle Time - 375,000 mi / 600,000 km / 8,450 hrs / 48 mo (4 yrs)**

---

<sup>5</sup> Ensure that all maintenance intervals leading up to this point are repeated during this interval prior to the completion of those listed here.

<sup>6</sup> Ensure that all maintenance intervals leading up to this point are repeated during this interval prior to the completion of those listed here.

2

**Less than 20% Idle Time - 375,000 mi / 600,000 km / 8,450 hrs / 48 mo (4 yrs) <sup>7</sup>**

Open Crankcase Ventilation

- Replace filter and o-ring gaskets when the OCV is serviced..

**Less than 20% Idle Time - 450,000  
mi / 725,000 km / 13,500 hrs / 48 mo  
(4 yrs)**

**Less than 20% Idle Time - 450,000 mi / 725,000 km / 13,500 hrs / 48 mo (4 yrs) <sup>8</sup>**

Drive Belts

- Refer to [Poly V-belt and Fan Drive Belt Removal](#) on page 88 - Replace for maintenance instructions.

**Less than 20% Idle Time - 600,000  
mi / 965,000 km / 18,000 hrs / 72 mo  
(6 yrs)**

---

<sup>7</sup> Ensure that all maintenance intervals leading up to this point are repeated during this interval prior to the completion of those listed here.

<sup>8</sup> Ensure that all maintenance intervals leading up to this point are repeated during this interval prior to the completion of those listed here.



<b>Less than 20% Idle Time - 600,000 mi / 965,000 km / 18,000 hrs / 72 mo (6 yrs) <sup>9</sup></b>
Aftertreatment System <ul style="list-style-type: none"> <li>Refer to <a href="#">Diesel Particulate Filter (DPF) Service Strategy</a> on page 90 - Wet Cleaning Strategy for maintenance instructions.</li> </ul>

**Less than 20% Idle Time - 750,000 mi / 1,200,000 km / 24,000 hrs / 96 mo (8 yrs)**

<b>Less than 20% Idle Time - 750,000 mi / 1,200,000 km / 24,000 hrs / 96 mo (8 yrs) <sup>10</sup></b>
Cooling System <ul style="list-style-type: none"> <li>Refer to Change <a href="#">Extended Life Coolant</a> on page 63 for maintenance instructions.</li> </ul>

**Greater than 20% Idle Time**

**Greater than 20% Idle Time - 25,000 mi / 40,000 km / 750 hrs / 6 mo**

<sup>9</sup> Ensure that all maintenance intervals leading up to this point are repeated during this interval prior to the completion of those listed here.

<sup>10</sup> Ensure that all maintenance intervals leading up to this point are repeated during this interval prior to the completion of those listed here.

**Greater than 20% Idle Time - 25,000 mi / 40,000 km / 750 hrs / 6 mo <sup>11</sup>**

Air System & Compressor

- Refer to [Air Compressor](#) on page 93 for maintenance instructions.
- Refer to [Engine Air Filters](#) on page 93 for maintenance instructions.

Charge Air System

- Refer to [Charge Air Piping](#) on page 93 for maintenance instructions.
- Refer to [Charge Air Cooler](#) on page 93 for maintenance instructions.

Charging / Cranking System

- Refer to [Electrical Harness / Cables](#) on page 95 for maintenance instructions.

Cooling System

- Refer to [Coolant/Antifreeze Condition](#) on page 82 for maintenance instructions.

**Greater than 20% Idle Time - 50,000 mi / 80,000 km / 1,500 hrs / 12 mo (1 yr)**

**Greater than 20% Idle Time - 50,000 mi / 80,000 km / 1,500 hrs / 12 mo (1 yr) <sup>12</sup>**

Charging / Cranking System

- Refer to [Batteries, Cables, and Connections](#) on page 95 for maintenance instructions.

<sup>11</sup> Ensure that all maintenance intervals leading up to this point are repeated during this interval prior to the completion of those listed here.

<sup>12</sup> Ensure that all maintenance intervals leading up to this point are repeated during this interval prior to the completion of those listed here.

<b>Greater than 20% Idle Time - 50,000 mi / 80,000 km / 1,500 hrs / 12 mo (1 yr) <sup>12</sup></b>
<p>Drive Belts</p> <ul style="list-style-type: none"> <li>Refer to <a href="#">Engine Belt Checks</a> on page 87 for maintenance instructions.</li> <li>Refer to <a href="#">Fan Belt Tensioner (If So Equipped)</a> on page 87 for maintenance instructions.</li> </ul>
<p>Engine Lubrication</p> <ul style="list-style-type: none"> <li>Refer to <a href="#">Engine Lubrication and Filter Intervals</a> on page 57 for maintenance instructions.</li> </ul>
<p>Fuel System</p> <ul style="list-style-type: none"> <li>Refer to <a href="#">Fuel Filter</a> on page 76 - Replace<sup>13</sup></li> </ul>

**Greater than 20% Idle Time -  
150,000 mi / 240,000 km / 4,500 hrs /  
24 mo (2 yrs)**

<b>Greater than 20% Idle Time - 150,000 mi / 240,000 km / 4,500 hrs / 24 mo (2 yrs) <sup>14</sup></b>
<p>Cooling System</p> <ul style="list-style-type: none"> <li>Refer to <a href="#">Radiator Hoses</a> on page 83 for maintenance instructions.</li> </ul>
<p>Crankshaft</p> <ul style="list-style-type: none"> <li>Refer to <a href="#">Crankshaft - Vibration Damper</a> on page 96 for maintenance instructions.</li> </ul>

<sup>12</sup> **Ensure that all maintenance intervals leading up to this point are repeated during this interval prior to the completion of those listed here.**

<sup>13</sup> Use of poor quality fuel may require more frequent fuel filter element service.

<sup>14</sup> **Ensure that all maintenance intervals leading up to this point are repeated during this interval prior to the completion of those listed here.**

**Greater than 20% Idle Time - 150,000 mi / 240,000 km / 4,500 hrs / 24 mo (2 yrs) <sup>14</sup>**

Mounting Bolts

- Refer to [Engine Mounting Bolts](#) on page 96 for maintenance instructions.

**Greater than 20% Idle Time -  
300,000 mi / 480,000 km / 6,750 hrs /  
36 mo (3 yrs)**

**Greater than 20% Idle Time - 300,000 mi / 480,000 km / 6,750 hrs / 36 mo (3 yrs) <sup>15</sup>**

Aftertreatment System

- Refer to [Diesel Particulate Filter \(DPF\) Service Strategy](#) on page 90 - Dry Cleaning Strategy.
- Refer to [Diesel Exhaust Fluid \(DEF\) Filter](#) on page 91 for maintenance instructions.

Cooling System

- Refer to [Replace Coolant Filter](#) on page 83 for maintenance instructions.

**Greater than 20% Idle Time -  
350,000 mi / 560,000 km / 7,850 hrs /  
48 mo (4 yrs)**

---

<sup>14</sup> Ensure that all maintenance intervals leading up to this point are repeated during this interval prior to the completion of those listed here.

<sup>15</sup> Ensure that all maintenance intervals leading up to this point are repeated during this interval prior to the completion of those listed here.

**Greater than 20% Idle Time - 350,000 mi / 560,000 km / 7,850 hrs / 48 mo (4 yrs) <sup>16</sup>**

## Open Crankcase Ventilation

- Replace filter and o-ring gaskets when the OCV is serviced.

**Greater than 20% Idle Time -  
450,000 mi / 725,000 km / 13,500  
hrs / 48 mo (4 yrs)****Greater than 20% Idle Time - 450,000 mi / 725,000 km / 13,500 hrs / 48 mo (4 yrs) <sup>17</sup>**

## Drive Belts

- Refer to [Poly V-belt and Fan Drive Belt Removal](#) on page 88 - Replace for maintenance instructions.

**Greater than 20% Idle Time -  
600,000 mi / 965,000 km / 18,000  
hrs / 72 mo (6 yrs)**

<sup>16</sup> Ensure that all maintenance intervals leading up to this point are repeated during this interval prior to the completion of those listed here.

<sup>17</sup> Ensure that all maintenance intervals leading up to this point are repeated during this interval prior to the completion of those listed here.

**Greater than 20% Idle Time - 600,000 mi / 965,000 km / 18,000 hrs / 72 mo (6 yrs) <sup>18</sup>**

Aftertreatment System

- Refer to [Diesel Particulate Filter \(DPF\) Service Strategy](#) on page 90 - Wet Cleaning Strategy for maintenance instructions.

**Greater than 20% Idle Time -  
750,000 mi / 1,200,000 km / 24,000  
hrs / 96 mo (8 yrs)**

**Greater than 20% Idle Time - 750,000 mi / 1,200,000 km / 24,000 hrs / 96 mo (8 yrs) <sup>19</sup>**

Cooling System

- Refer to Change [Extended Life Coolant](#) on page 63 for maintenance instructions.

Crane, Dumps, Emergency/Fire, Heavy Equipment, Loggers, Mining, Oil Field, Snowplows, and Wrecker.

**Severe Duty/Vocational - 15,000 mi /  
24,000 km / 400 hrs / 6 mo**

## Severe Duty/Vocational

Vocational vehicle applications include:  
Agriculture, Concrete Mixers, Construction,

---

<sup>18</sup> Ensure that all maintenance intervals leading up to this point are repeated during this interval prior to the completion of those listed here.

<sup>19</sup> Ensure that all maintenance intervals leading up to this point are repeated during this interval prior to the completion of those listed here.

<b>Severe Duty/Vocational - 15,000 mi / 24,000 km / 400 hrs / 6 mo <sup>20</sup></b>
<p>Air system and compressor</p> <ul style="list-style-type: none"> <li>Refer to <a href="#">Air Compressor</a> on page 93 for maintenance instructions.</li> <li>Refer to <a href="#">Engine Air Filters</a> on page 93 for maintenance instructions.</li> </ul>
<p>Charge Air System</p> <ul style="list-style-type: none"> <li>Refer to <a href="#">Charge Air Piping</a> on page 93 for maintenance instructions.</li> <li>Refer to <a href="#">Charge Air Cooler</a> on page 93 for maintenance instructions.</li> </ul>
<p>Charging/Cranking System</p> <ul style="list-style-type: none"> <li>Refer to <a href="#">Electrical Harness / Cables</a> on page 95 for maintenance instructions.</li> </ul>
<p>Cooling System</p> <ul style="list-style-type: none"> <li>Refer to <a href="#">Coolant/Antifreeze Condition</a> on page 82 for maintenance instructions.</li> </ul>

**Severe Duty/Vocational - 30,000 mi / 48,000 km / 800 hrs / 12 mo (1 yr)**

<b>Severe Duty/Vocational - 30,000 mi / 48,000 km / 800 hrs / 12 mo (1 yr) <sup>21</sup></b>
<p>Charging / Cranking System</p> <ul style="list-style-type: none"> <li>Refer to <a href="#">Batteries, Cables, and Connections</a> on page 95 for maintenance instructions.</li> </ul>

<sup>20</sup> Ensure that all maintenance intervals leading up to this point are repeated during this interval prior to the completion of those listed here.

<sup>21</sup> Ensure that all maintenance intervals leading up to this point are repeated during this interval prior to the completion of those listed here.

**Severe Duty/Vocational - 30,000 mi / 48,000 km / 800 hrs / 12 mo (1 yr) <sup>21</sup>**

Drive Belts

- Refer to [Engine Belt Checks](#) on page 87 for maintenance instructions.
- Refer to [Fan Belt Tensioner \(If So Equipped\)](#) on page 87 for maintenance instructions.

Engine Lubrication

- Refer to [Engine Lubrication and Filter Intervals](#) on page 57 for maintenance instructions.

Fuel System

- Refer to [Fuel Filter](#) on page 76 - Replace<sup>22</sup>

**Severe Duty/Vocational - 60,000 mi /  
96,000 km / 1,600 hrs / 24 mo (2 yrs)**

**Severe Duty/Vocational - 60,000 mi / 96,000 km / 1,600 hrs / 24 mo (2 yrs) <sup>23</sup>**

Cooling System

- Refer to [Radiator Hoses](#) on page 83 for maintenance instructions.

Crankshaft

- Refer to [Crankshaft - Vibration Damper](#) on page 96 for maintenance instructions.

<sup>21</sup> **Ensure that all maintenance intervals leading up to this point are repeated during this interval prior to the completion of those listed here.**

<sup>22</sup> Use of poor quality fuel may require more frequent fuel filter element service.

<sup>23</sup> **Ensure that all maintenance intervals leading up to this point are repeated during this interval prior to the completion of those listed here.**



<b>Severe Duty/Vocational - 60,000 mi / 96,000 km / 1,600 hrs / 24 mo (2 yrs) <sup>23</sup></b>
<p>Mounting Bolts</p> <ul style="list-style-type: none"> <li>Refer to <a href="#">Engine Mounting Bolts</a> on page 96 for maintenance instructions.</li> </ul>

**Severe Duty/Vocational - 150,000 mi / 240,000 km / 4,500 hrs / 24 mo (2 yrs)**

<b>Severe Duty/Vocational - 150,000 mi / 240,000 km / 4,500 hrs / 24 mo (2 yrs) <sup>24</sup></b>
<p>Aftertreatment System</p> <ul style="list-style-type: none"> <li>Refer to <a href="#">Diesel Particulate Filter (DPF) Service Strategy</a> on page 90 - Dry Cleaning Strategy.</li> </ul>

**Severe Duty/Vocational - 180,000 mi / 290,000 km / 5,400 hrs / 36 mo (3 yrs)**

---

<sup>23</sup> Ensure that all maintenance intervals leading up to this point are repeated during this interval prior to the completion of those listed here.

<sup>24</sup> Ensure that all maintenance intervals leading up to this point are repeated during this interval prior to the completion of those listed here.

**Severe Duty/Vocational - 180,000 mi / 290,000 km / 5,400 hrs / 36 mo (3 yrs) <sup>25</sup>**

Open Crankcase Ventilation

- Replace filter and o-ring gaskets when the OCV is serviced.

**Severe Duty/Vocational - 300,000  
mi / 480,000 km / 9,000 hrs / 36 mo  
(3 yrs)**

**Severe Duty/Vocational - 300,000 mi / 480,000 km / 9,000 hrs / 36 mo (3 yrs) <sup>26</sup>**

Aftertreatment System

- Refer to *Diesel Exhaust Fluid (DEF) Filter* on page 91 for maintenance instructions.

Cooling System

- Refer to *Replace Coolant Filter* on page 83 for maintenance instructions.

**Severe Duty/Vocational - 450,000  
mi / 725,000 km / 13,500 hrs / 48 mo  
(4 yrs)**

---

<sup>25</sup> Ensure that all maintenance intervals leading up to this point are repeated during this interval prior to the completion of those listed here.

<sup>26</sup> Ensure that all maintenance intervals leading up to this point are repeated during this interval prior to the completion of those listed here.

**Severe Duty/Vocational - 450,000 mi / 725,000 km / 13,500 hrs / 48 mo (4 yrs)<sup>27</sup>**

Drive Belts

- Refer to *Poly V-belt and Fan Drive Belt Removal* on page 88 - Replace for maintenance instructions.

**Severe Duty/Vocational - 750,000 mi / 1,200,000 km / 24,000 hrs / 96 (8 yrs)**

**Severe Duty/Vocational - 750,000 mi / 1,200,000 km / 24,000 hrs / 96 (8 yrs)<sup>28</sup>**

Cooling System

- Refer to Change *Extended Life Coolant* on page 63 for maintenance instructions.

**Pick-up/Delivery/Refuse - 15,000 mi / 24,000 km / 400 hrs / 6 mo**

**Pick-up/Delivery/Refuse**

<sup>27</sup> Ensure that all maintenance intervals leading up to this point are repeated during this interval prior to the completion of those listed here.

<sup>28</sup> Ensure that all maintenance intervals leading up to this point are repeated during this interval prior to the completion of those listed here.

**Pick-up/Delivery/Refuse - 15,000 mi / 24,000 km / 400 hrs / 6 mo <sup>29</sup>**

Air system and compressor

- Refer to [Air Compressor](#) on page 93 for maintenance instructions.
- Refer to [Engine Air Filters](#) on page 93 for maintenance instructions.

Charge Air System

- Refer to [Charge Air Piping](#) on page 93 for maintenance instructions.
- Refer to [Charge Air Cooler](#) on page 93 for maintenance instructions.

Charging/Cranking System

- Refer to [Electrical Harness / Cables](#) on page 95 for maintenance instructions.

Cooling System

- Refer to [Coolant/Antifreeze Condition](#) on page 82 for maintenance instructions.

**Pick-up/Delivery/Refuse - 30,000  
mi / 48,000 km / 800 hrs / 12 mo  
(1yr)**

---

<sup>29</sup> Ensure that all maintenance intervals leading up to this point are repeated during this interval prior to the completion of those listed here.

<b>Pick-up/Delivery/Refuse - 30,000 mi / 48,000 km / 800 hrs / 12 mo (1yr) <sup>30</sup></b>
<p>Charging / Cranking System</p> <ul style="list-style-type: none"> <li>Refer to <a href="#">Batteries, Cables, and Connections</a> on page 95 for maintenance instructions.</li> </ul>
<p>Drive Belts</p> <ul style="list-style-type: none"> <li>Refer to <a href="#">Engine Belt Checks</a> on page 87 for maintenance instructions.</li> <li>Refer to <a href="#">Fan Belt Tensioner (If So Equipped)</a> on page 87 for maintenance instructions.</li> </ul>
<p>Engine Lubrication</p> <ul style="list-style-type: none"> <li>Refer to <a href="#">Engine Lubrication and Filter Intervals</a> on page 57 for maintenance instructions.</li> </ul>
<p>Fuel System</p> <ul style="list-style-type: none"> <li>Refer to <a href="#">Fuel Filter</a> on page 76 - Replace<sup>31</sup></li> </ul>

**Pick-up/Delivery/Refuse - 60,000 mi / 96,000 km / 1,600 hrs / 12 mo (1 yr)**

<sup>30</sup> Ensure that all maintenance intervals leading up to this point are repeated during this interval prior to the completion of those listed here.

<sup>31</sup> Use of poor quality fuel may require more frequent fuel filter element service.

**Pick-up/Delivery/Refuse - 60,000 mi / 96,000 km / 1,600 hrs / 12 mo (1 yr) <sup>32</sup>**

Cooling System

- Refer to [Radiator Hoses](#) on page 83 for maintenance instructions.

Crankshaft

- Refer to [Crankshaft - Vibration Damper](#) on page 96 for maintenance instructions.

Mounting Bolts

- Refer to [Engine Mounting Bolts](#) on page 96 for maintenance instructions.

**Pick-up/Delivery/Refuse - 90,000  
mi / 144,000 km / 1,600 hrs / 12 mo  
(1 yr)**

**Pick-up/Delivery/Refuse - 90,000 mi / 144,000 km / 1,600 hrs / 12 mo (1 yr) <sup>33</sup>**

Aftertreatment System

- Refer to [Diesel Particulate Filter \(DPF\) Service Strategy](#) on page 90 - Dry Cleaning Strategy.

**Pick-up/Delivery/Refuse - 125,000  
mi / 200,000 km / 4,500 hrs / 24 mo  
(2 yrs)**

<sup>32</sup> Ensure that all maintenance intervals leading up to this point are repeated during this interval prior to the completion of those listed here.

<sup>33</sup> Ensure that all maintenance intervals leading up to this point are repeated during this interval prior to the completion of those listed here.

**Pick-up/Delivery/Refuse - 125,000 mi / 200,000 km / 4,500 hrs / 24 mo (2 yrs) <sup>34</sup>**

Open Crankcase Ventilation

- Replace filter and o-ring gaskets when the OCV is serviced.

**Pick-up/Delivery/Refuse - 300,000 mi / 480,000 km / 9,000 hrs / 36 mo (3yrs)**

**Pick-up/Delivery/Refuse - 300,000 mi / 480,000 km / 9,000 hrs / 36 mo (3yrs) <sup>35</sup>**

Aftertreatment System

- Refer to [Diesel Exhaust Fluid \(DEF\) Filter](#) on page 91 for maintenance instructions.

Cooling System

- Refer to [Replace Coolant Filter](#) on page 83 for maintenance instructions.

**Pick-up/Delivery/Refuse - 450,000 mi / 725,000 km / 13,500 hrs / 48 mo (4yrs)**

<sup>34</sup> Ensure that all maintenance intervals leading up to this point are repeated during this interval prior to the completion of those listed here.

<sup>35</sup> Ensure that all maintenance intervals leading up to this point are repeated during this interval prior to the completion of those listed here.

**Pick-up/Delivery/Refuse - 450,000 mi / 725,000 km / 13,500 hrs / 48 mo (4yrs) <sup>36</sup>**

Drive Belts

- Refer to [Poly V-belt and Fan Drive Belt Removal](#) on page 88 - Replace for maintenance instructions.

**Pick-up/Delivery/Refuse - 750,000 mi / 1,200,000 km / 24,000 hrs / 96 (8 yrs)**

**Pick-up/Delivery/Refuse - 750,000 mi / 1,200,000 km / 24,000 hrs / 96 (8 yrs) <sup>37</sup>**

Cooling System

- Refer to Change [Extended Life Coolant](#) on page 63 for maintenance instructions.

## Engine Specifications

### PACCAR MX-13 Engine Specifications

Horsepower	See the EPA label on top of the valve cover or on the mixer manifold.
------------	---

<sup>36</sup> Ensure that all maintenance intervals leading up to this point are repeated during this interval prior to the completion of those listed here.

<sup>37</sup> Ensure that all maintenance intervals leading up to this point are repeated during this interval prior to the completion of those listed here.



Firing Order	1, 5, 3, 6, 2, 4
Crankshaft Rotation (viewed from front of engine)	Clockwise
Displacement	787 CID (12.9 liters)
Bore and Stroke	5.12 in. (130 mm) × 6.38 in. (162 mm)
Dry Weight (excludes Flywheel and Air Compressor)	2,600 lb (1,179 kg)
Idle Speed	Approximately 550-650 rpm
High Idle speed (low hp/high hp)	2,100/2,200 rpm
Maximum continuous engine speed with engine brake active	2,100 rpm
Fault code registers with engine brake active	2,300 rpm
Maximum Continuous No Load Governed Speed	2,200 rpm
Engine Over Speed	2,301 to 2,499 rpm
Misuse	2,300 rpm or greater
REPTO Rotation and Ratio	Clockwise, 1.2:1
REPTO Torque Limit	613 lb-ft (continuous)
FEPTO Torque Limit	515 lb-ft (continuous)

**Filter Specifications**

PACCAR is not responsible for problems caused by non-genuine filters that do not

meet PACCAR performance or durability requirements.

Contact your local PACCAR authorized repair location for specific part numbers.



**CAUTION**

Use of non-genuine PACCAR oil filters can cause severe engine damage.

2

## Engine Lubricating Oil Recommendations and Specifications

A major factor in maintaining engine performance and durability is the proper use of quality engine lubricating oils used in conjunction with the appropriate oil drain and filter change intervals. Attempting to extend the oil and filter change interval beyond the manufacturers recommendations may decrease engine life due to factors such as corrosion, deposits, and wear. See Engine Lubrication and Filter Intervals to determine which oil drain interval to use for an application.



**NOTE**

It is the operator's responsibility to follow these recommendations to ensure that the engine warranty is not affected.

PACCAR recommends the use of high-quality SAE 10W-30 API CK-4/CJ-4 heavy-duty engine oil.

The primary PACCAR recommendation is for the use of 10W-30 multigrade lubricating oil for normal operation at ambient temperatures above 5°F (-15°C). For ambient temperatures below 5°F (-15°C) SAE 5W-30 may be used, provided it meets API CK-4/CJ-4 oil specifications and biodiesel or biodiesel blended fuel is not used as fuel for the engine. Using a multigrade oil helps improve engine cranking in low-temperature conditions, reduces deposit formation, increases engine durability and increases fuel economy.

Engine Oil Viscosity Chart

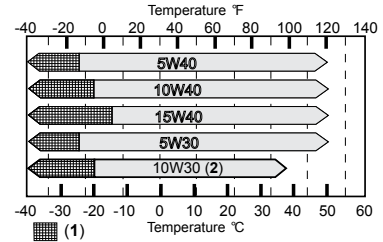

1. If engine is equipped with an active oil pan heater, use before engine start.
2. Initial factory oil fill: API CK-4 10W-30



**NOTE**

Any of the oil weights listed in the chart above are acceptable to use as long as the oil meets API CK-4/CJ-4 oil specifications.

### New Engine Break-In Oils

PACCAR does not approve the use of special "break-in" engine lubricating oils for new or rebuilt PACCAR engines. It is recommended to use the same lubricating

oil for engine break-in that will be used during normal operation.

**Aftermarket Oil Additive Usage**

PACCAR does not recommend the use of aftermarket oil additives. Today's high-quality engine lubricating oils are very sophisticated. Most oils already contain precise amounts of additives blended into

the lubricating oil to meet stringent performance requirements. These oils meet performance characteristics that conform to the lubricant industry standards and are sufficient protection when used according to the recommendations. Aftermarket lubricating oil additives are not necessary to enhance engine oil performance and may in some

cases reduce the oil's capability to protect the engine.

**Engine Oil Capacities and Pressures**

**Engine Oil Capacity and Acceptable Pressures**

PACCAR MX-13 - High and Low Horsepower Ratings	
Oil Pressure at low idle (min. allowable) 650 ± 50 rpm	14.5 psi at 239°F (100 kPa at 115°C) oil temperature
At road speed 900-1,200 rpm (min. allowable)	20-29 psi at 239°F (140-200 kPa at 115°C) oil temperature
At road speed 1,200-2,100 rpm (min. allowable)	29 psi at 239°F (200 kPa at 115°C) oil temperature
Regulated oil pressure (nominal)	33 psi at 239°F (230 kPa at 115°C) oil temperature
Total system capacity (oil pan and new oil filters)	42 U.S. qts. (40.0 liters)

**Engine Lubrication and Filter Intervals**

Oil drain interval recommendations are based on vehicle application or engine duty

cycle. PACCAR recommends the use of high quality lubricating oil as indicated in the Engine Lubricating Oil Recommendations and Specifications section. Perform these maintenance procedures according to the Preventive Maintenance Schedule.



**CAUTION**

Extending the oil and filter change interval beyond the recommendations

will decrease the engine life due to factors such as corrosion, deposits, and wear. Engine oil filters capture dirt and remove deposits from the oil to prolong the life of internal moving com-

ponents. Follow the oil and filter change intervals as recommended in this section of the manual. Failure to comply may result in equipment or property damage.

2

**Determining Type of Vehicle Application for Engine Oil Drain Intervals**

	<b>Severe Duty - Vocational *</b>	<b>Normal Duty - Line Haul</b>
Fuel Consumption	Less than 6 MPG (2.6 km/L)	6 MPG (2.6 km/L) or greater
Gross Vehicle Weight	Greater than 80,000 lb. (36,300 kg)	80,000 lb. (36,300 kg) or less
* Vocational vehicle applications include: Agriculture, Concrete Mixers, Construction, Crane, Dumps, Emergency/Fire, Heavy Equipment, Loggers, Mining, Oil Field, Snowplows, and Wrecker.		

**Engine Oil and Filter Change Intervals**

	Vehicle Application	Change Interval
Oil Drain and Filter Replacement Interval	Normal Duty (Line Haul) - less than 20% idle time	75,000 miles (120,000 km) 2,250 hours or 12 months
	Normal Duty (Line Haul) - more than 20% idle time	50,000 miles (80,000 km) 1,500 hours or 12 months
	Severe Duty (Vocational*)	30,000 miles (48,000 km) 800 hours, or 12 months
* Vocational vehicle applications include: Agriculture, Concrete Mixers, Construction, Crane, Dumps, Emergency/Fire, Heavy Equipment, Loggers, Mining, Oil Field, Snowplows, and Wrecker.		

**i** NOTE  
If B6-B20 biodiesel fuel is used, the oil and filter must be changed every 40,000 mi (64,000 km) for line haul applications; every 20,000 mi (32,000

km) for severe duty, or every six months.

**Cooling System Maintenance**

The cooling system in your vehicle was factory filled with extended life coolant that meets or exceeds all ASTM D6210 and Caterpillar EC-1 requirements. PACCAR

recommends only using a 50/50 mixture of distilled water and ELC when cooling system service is required. A 50/50 mixture of ELC and distilled water will provide freeze protection down to -34°F (-36.7°C), which is adequate for most locations in North America. For extremely cold operating conditions, a 60/40 mixture (coolant/water ratio) can be used to provide freeze protection down to -62°F (-52.2°C).

Unless otherwise optioned, factory fill coolant is an ethylene glycol, nitrated organic acid technology (NOAT) extended life coolant (ELC) formulation at a 50:50 coolant-to-distilled water mixture. The factory fill exceeds ASTM D6210 and Caterpillar EC-1 requirements. Maintaining coolant chemistry and freeze protection is critical to engine and cooling system component health and longevity.



**WARNING**

Coolant is toxic. DO NOT get the fluid in eyes. If contact occurs, flood eyes with large amounts of water for 15 minutes. Avoid prolonged or repeated contact with skin. In case of contact, immediately wash skin with soap and

water. DO NOT take internally. If swallowed, seek immediate medical attention. DO NOT induce vomiting. Failure to comply may result in death, personal injury, equipment or property damage.



**CAUTION**

The engine cooling system has very specific maintenance and inspection requirements. Failure to follow requirements can damage the engine. Engine damage can include but is not limited to freezing, boiling, corrosion, pitted cylinder liners. This information is found in the engine manufacturers owner's manual. It is the owner's responsibility to follow all requirements listed in the engine manufacturers owner's manual.



**NOTE**

Coolant is harmful to the environment. Unused coolant must be stored as a toxic hazardous material in leakproof containers. Used coolant must be

processed as industrial chemical waste. Please follow HAZMAT guidelines with both used and unused coolants.



**CAUTION**

Use of non-genuine PACCAR coolant filters may cause severe engine damage.

**Concentration**

Check the level of freeze/boil over protection, which is determined by the glycol concentration. Use a glycol refractometer to determine glycol level. Add coolant to obtain the coolant/water ratio required to provide the protection you need. A 50/50 mix of coolant and water is adequate for most applications. For extremely cold operating conditions, the ratio can be adjusted to a higher concentration of coolant.

 <b>NOTE</b>
Maximum recommended ELC concentration is 60% ELC and 40% water by volume (a 60/40 coolant mixture). The minimum recommended concentration is 40%.

**Glycol Concentration Level**

Level	Desired Coolant / Water Ratio	Freeze Point °F (°C)
Recommended Levels	40%	-12 (-24)
	45%	-23 (-31)
	50%	-34 (-37)
	55%	-50 (-46)
	60%	-62 (-52)

**Condition**

Perform a visual inspection of the coolant. It should have no cloudiness or floating debris. Determine the chemical inhibitor concentration level by using an extended life coolant specific test kit or test strips. Inhibitor concentration level determines corrosion protection. If you are concerned about possible coolant quality, contamination, or mechanical problems, submit a coolant sample for analysis. Improper maintenance may cause coolant degradation and could result in damage to the cooling system and engine components. Consult your dealer or the coolant manufacturer's representative for recommended extended life coolant test kits, test strips, and laboratory sample procedures.

**Coolant Extender**

Add extended life coolant extender, if necessary, according to the corrosion inhibitor concentration required. **DO NOT** add coolant extender to nitrite-free coolant.

**Checking Coolant Level**

Check the coolant level daily. See [Coolant Level](#) on page 33.



**CAUTION**

When adding coolant, avoid mixing different brands and formulations. If the coolant is mixed with more than 25% of a different formulation (for example, mixing OAT and NOAT coolants), engine corrosion damage could occur. If mixing exceeds 25% of total system volume, it is recommended to flush and refill the system completely with one type of coolant.

**Coolant Filter**

Your engine is equipped with a coolant filter designed to capture and remove harmful deposits from the cooling system to help prolong system life. It is a "blank filter" and does not contain chemicals or time-release additives. Replace it only with a blank filter at the interval specified in the Preventative Maintenance Schedule. **NEVER** use filters that contain supplemental coolant additives (SCAs) in an ELC-filled system.



**CAUTION**

Use of non-genuine PACCAR coolant filters may cause severe engine damage.

**Cooling System Sealing Additives and Soluble Oils**

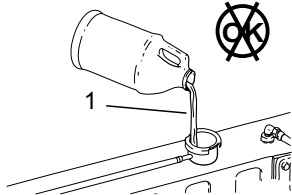

1. Do not use soluble oils or sealing additives.



**CAUTION**

The use of sealing additives or soluble oils in the cooling system can cause damage to the engine. These additives can plug various areas of the radiator,

EGR system and oil cooler. The plugging of the cooling system can hamper heat transfer, causing internal engine damage. **DO NOT** use sealing additives or soluble oils in the cooling system. The use of sealing additives can:

- Build up in coolant low-flow areas
- Plug the radiator and oil cooler
- Damage the water pump seal
- Damage heat transfer surfaces
- Damage seals and hoses
- Corrode brass and copper

Failure to comply may result in equipment or property damage.

**Engine Coolant Specifications**

**Engine Coolant Specifications for PACCAR MX-13**

Coolant Capacity	Approx. 13 gallons <sup>38</sup> (49 liters)
Minimum Recommended Pressure Cap	15 psi (103 kPa)
Maximum Engine Coolant Outlet Temperature	223°F (106°C)



**NOTE**

Coolant volumes are dependent on chassis model and cab/sleeper heater options.

<sup>38</sup> Varies with vehicle equipment



## Extended Life Coolant

Perform these maintenance procedures according to the Preventative Maintenance Schedule.

- Conduct coolant maintenance checks including freeze point, pH, nitrite and carboxylate tests at least twice annually to maintain engine protection.

### Nitrited Extended Life Coolant

For nitrited formulations (NOAT), a heavy-duty extended life coolant that meets ASTM D6210 and Caterpillar EC-1 specifications must be used.

Unless otherwise optioned, factory fill coolant is an ethylene glycol, nitrited organic acid technology (NOAT) extended life coolant (ELC) formulation at a 50:50 coolant-to-distilled water mixture. The factory fill exceeds ASTM D6210 and Caterpillar EC-1 requirements. Maintaining coolant chemistry and freeze protection is critical to engine and cooling system component health and longevity. The change interval for extended-life coolant containing nitrite and molybdate is 750,000 miles (1,200,000 km) or 12,000

hours of on-road use (8 years or 15,000 hours of off-highway use) on initial fill with no extender added. The change interval is 1,000,000 miles (1,600,000 km)/20,000 hours/8 years with an extender addition at 500,000 miles (800,000 km)/10,000 hours/4 years.

### Nitrite-Free Extended Life Coolant

Nitrite-free organic acid technology coolant (OAT) may be used if it meets DAF 74002. The change interval for nitrite free coolant is 600,000 miles (1,000,000 km) or 6 years, with no extender needed. DO NOT add coolant extender to nitrite-free coolant. Follow the coolant supplier's drain/flush/fill/diluting percentages when servicing a vehicle filled with nitrite-free coolant.

Additional Recommendations:

- Antifreeze is essential for freeze, overheat, and corrosion protection. The use of supplemental coolant additives (SCAs) is not recommended for extended-life coolants.

## Recommended Extended Life Coolant Suppliers

Authorized PACCAR Engine dealer



## Fuel Recommendations

 <b>WARNING</b>
<p>The use of diesel fuel that has been mixed with other fuels may cause an explosion. DO NOT mix gasoline, alcohol, or gasohol with diesel fuel. Make sure you know your fuel source and use the recommended diesel fuel as indicated in this section of the manual. Failure to comply may result in death, personal injury, equipment or property damage.</p>



**CAUTION**

Dirt or water in the fuel system can cause severe damage to both the fuel pump and the fuel injectors. Due to the precise tolerances of diesel injection systems, it is extremely important that the fuel be kept clean and free of dirt or water. Know your fuel source and make sure all steps are taken for dispensing or using clean fuel in your vehicle. Failure to comply may result in equipment or property damage.



**CAUTION**

Unapproved fuel can reduce economy or possibly damage fuel system components. Unapproved fuels typically do not have enough lubricity elements in the fuel to properly lubricate the fuel injection system. Be sure you follow the fuel recommendations as indicated in this section of the manual. Failure to comply may result in equipment or property damage.



**CAUTION**

Using diesel fuels blended with lubricants may cause damage to your engine aftertreatment system. Service intervals for engine aftertreatment systems will be reduced. DO NOT use diesel fuel blended with lubricating oil in engines equipped with an engine aftertreatment system. Failure to comply may result in equipment or property damage.



**CAUTION**

DO NOT use high-sulfur diesel fuel as it will damage the exhaust aftertreatment system. Also, the engine will not meet emission regulations. Use only ultra-low-sulfur diesel (ULSD) fuel. Failure to comply may result in equipment or property damage.



**CAUTION**

If ultra-low-sulfur diesel (ULSD) fuel is not used, the engine may not meet

emission regulations, and damage may occur to the engine aftertreatment system. The use of high-sulfur diesel fuel will damage the engine aftertreatment system and impact the engine emission. ULSD fuel is required for correct operation of the aftertreatment. The engine has been optimized for use with an engine aftertreatment system together with ULSD fuel to meet the 2013 U.S. Environmental Protection Agency regulations. Failure to comply may result in equipment or property damage.



**NOTE**

PACCAR recommends that the cetane number of diesel fuel be a minimum of 45 for engines that are expected to operate at temperatures below 32°F (0°C) and a minimum of 42 for engines that are operated at temperatures above 32°F (0°C).

Using diesel fuel with a lower-than-recommended cetane number can cause hard starting instability, and excessive white smoke. To maintain satisfactory

operation at low ambient temperatures, it is important to specify diesel fuel of the correct cetane number.

PACCAR requires all permissible fuels to have adequate fuel lubricity. Lubricity can be determined by ASTM, specification D6079, ISO 12156, High Frequency Reciprocating Rig (HFRR) in which the fuel must have a wear scar diameter of 0.02 in. (0.5 mm) or less.

The use of Ultra-low-sulfur diesel (ULSD) fuel is required for this engine in order to meet emission regulations and to prevent damage to the engine and exhaust system. The use of other grades of diesel fuels other than ULSD fuel will be considered a use of incorrect fuel for the engine. PACCAR is not responsible for failures caused by the use of incorrect fuel, oil or DEF or by water, dirt or other contaminants in the fuel or DEF.

## Warranty and the Use of Renewable and Other Paraffinic Diesel Fuels

PACCAR Inc. approves the use of paraffinic diesel at any blend level or as a

stand-alone fuel, providing that the following conditions are met:

- The paraffinic diesel in the fuel meets EN 15940 specifications, and
- The finished fuel meets the properties of ASTM Standard D975

The use of approved paraffinic diesel fuel does not affect the PACCAR engine warranty, or its maintenance intervals. Failures caused by the use of fuels that are not approved, are of unacceptable quality, or do not meet specified industry standards are not considered as defects of parts or workmanship by PACCAR and therefore will not be covered by the PACCAR engine warranty. Specifically, raw or unprocessed vegetable oils differ heavily from paraffinic diesel and are not approved.

PACCAR recommends that customers intending to use paraffinic diesel become familiar with the properties of these fuels. Please reference the fuel supplier's technical information and request a copy of the certificate of analysis if it is unclear whether the fuel meets specifications. In particular, operators should be aware that paraffinic fuels are more prone to cold flow (gelling) and filter plugging issues if not formulated to meet climate-dependent requirements for the region. Operators

should also be aware that paraffinic diesel energy content (by volume) is lower than that of petroleum diesel, which can reduce fuel economy by up to four percent as a stand-alone fuel.

## Warranty and the Use of Biodiesel Fuel

PACCAR Inc. approves the use of biodiesel fuel blends up to 20 percent by volume in diesel fuel providing that the following conditions are met:

- The biodiesel used in the blend meets ASTM Standard D6751 or EN 14214 specifications.
- The biodiesel used in the blend is sourced from a BQ-9000 Accredited Producer.
- The finished blend meets the fuel properties of the ASTM Standard D975 (up to B5 blend) or D7467 (B6 to B20 blend).
- If using B6-B20 the engine oil and oil filter are changed per the modified schedule. See the Preventative Maintenance Schedule.

- If using B6-B20 the fuel filter is changed every 25,000 miles (40,000 km).

The use of approved biodiesel fuel does not affect the PACCAR engine warranty. Failures caused by the use of non-approved biodiesel fuels or other fuel additives that are of unacceptable quality or do not meet specified industry standards are not considered as defects of parts or workmanship by PACCAR and therefore will not be covered by the PACCAR engine warranty.

PACCAR recommends that customers intending to use biodiesel blends become familiar with the additional handling considerations of these fuels such as aging, metal compatibility and tendency to absorb water. Please reference the fuel supplier's technical information or industry guidelines such as the American Trucking Association Truck Maintenance Council document RP 357.

In particular, operators should be aware that biodiesel blends are more prone to cold flow (gelling) and filter plugging issues compared to conventional diesel fuel. If vehicles are expected to be operated in temperatures below freezing, care should be taken to ensure that both the biodiesel

fuel used and the appropriate vehicle fuel system accessory heaters are utilized. Operators should also be aware that biodiesel energy content (by volume) is lower than diesel which can reduce fuel economy by up to two percent.

### Recommendations to Avoid Fuel Gelling

To avoid fuel gelling in cold weather:

- Use appropriate fuel grade/blend for conditions
- Spec your vehicle with proper cold weather equipment (12V electric pre-heater, fuel/coolant heater, 12V fuel line heaters and fuel tank heaters)

PACCAR does not recommend the use of fuel additives, however, should a customer decide there is a need for temporary use of a winter fuel additive, PACCAR offers the following guidance:

- Use an industry known, high quality product (EPA-approved)
- Check the product label to ensure it is compatible with ultra-low sulfur

diesel fuel and aftertreatment systems

- Only use the additive for the minimum time needed
- Follow the additive manufacturer's instructions exactly

### Maintenance Procedures

#### Engine Oil Level

To check engine oil level, park vehicle on level ground and wait 15 minutes after shutting off engine. After the engine is shut off it will take at least 15 minutes for all the engine oil to return to the sump.



#### NOTE

It takes approximately 15 minutes for all the oil to run into the sump when the engine is 'warm.' If the level is checked immediately after switching off the engine, the dipstick will show a low oil level.

Make sure that the vehicle suspension is sitting flat, both lengthwise and crosswise.

Check this carefully on a vehicle with air suspension.

Engine coolant should be at or above the operating temperature of 180°F (82°C).

This procedure should be followed as part of routine maintenance checks.

1. Twist the dipstick handle to unlock it, then pull the dipstick out of the holder.

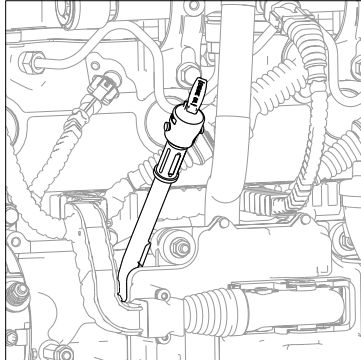

2. Wipe the dipstick clean with a lint-free cloth.
3. Reinsert the dipstick into the holder.
4. Remove the dipstick from the holder and check the oil level. The

oil level should always be between the two marks on the dipstick.

5. Reinstall the dipstick and twist to lock it in place.

### Oil Level Indication on Dipstick

<b>i</b>	<b>NOTE</b>
<p>On the engine oil dipstick, the difference between the low oil level mark (2) and high oil level mark (1) is 6.3 US quarts (6 liters).</p>	

### Engine Oil Dip Stick Markings

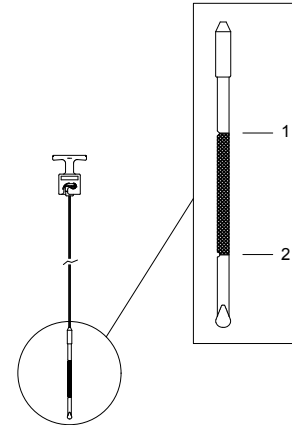

1. High oil level (1)
2. Low oil level (2)

### Topping Up the Engine Oil

If checking the engine oil just after stopping the engine, wait 15 minutes for the oil to drain back into the oil pan before checking the fluid level.

This procedure should be followed when oil level is low and more oil needs to be added.

1. Top up with oil, if necessary, via the filler opening. Use the correct grade in the correct quantity.
2. After topping up, wait one minute and check the oil level again.
3. Reinstall the oil fill cap and twist to lock it in place.

Engine Oil Fill Location

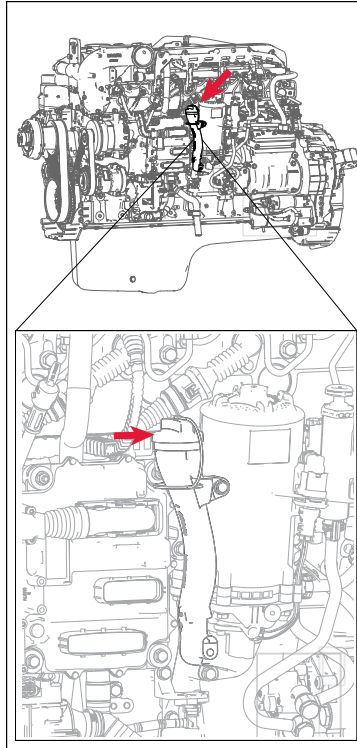

### Oil Drain Plug for Composite Pan



#### CAUTION

The drain plug is on the bottom of the oil pan. Do not use any other plug on the pan as a drain. Doing so may damage the pan, leak oil and damage the engine.

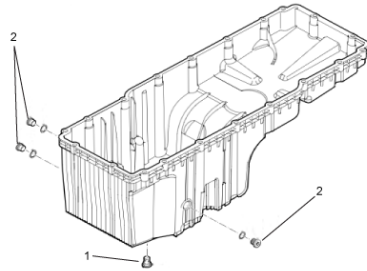

1. Drain Plug
2. Not drain plugs

**Oil Pan Drain Plug Installation**

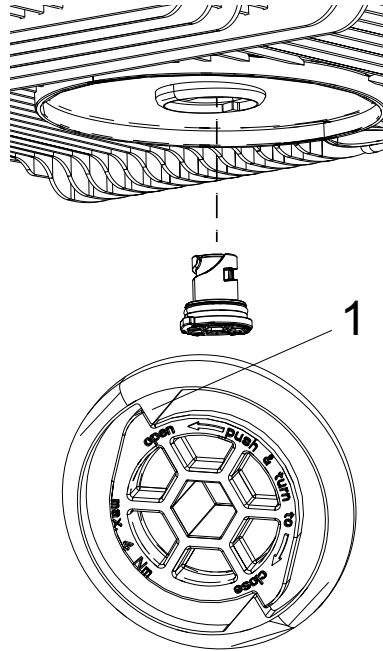

1. Stop  
Torque the drain plug to its stop.

**Oil Drain Plug Detent**

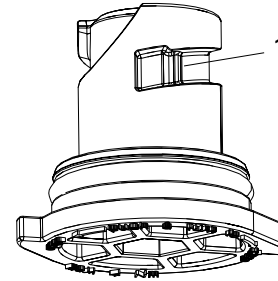

1. Detent



**NOTE**

Care should be taken to avoid over-torquing the drain plug.

Replace the drain plug if:

- The plug is leaking
- The O-ring is missing
- The plug/O-ring assembly is damaged
- The retention detent cannot be felt during installation

## Engine Oil Filter

### Oil Filter Module

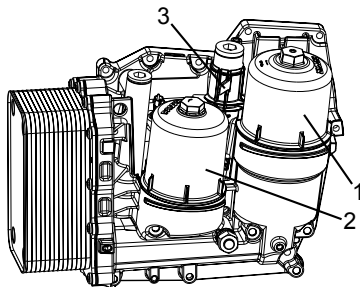

1. Full-Flow Oil Filter
2. Centrifugal Bypass Oil Filter
3. Oil Filter Cap Lock

Your engine is equipped with a full-flow oil filter and may also be equipped with a centrifugal bypass oil filter. Both filters are designed to capture contaminants and remove deposits from the oil to prolong the life of internal moving components.

Always use quality engine lubricating oils in conjunction with the appropriate oil drain and filter change intervals. Refer to the "Preventative Maintenance Schedule" for the recommended oil and filter change service interval.



### CAUTION

Use of non-genuine PACCAR oil filters can cause severe engine damage.

### Oil Filter Removal Preparation



### CAUTION

Before beginning to remove and/or disconnect any components, wait at least 5 minutes after the key switch is turned OFF for the aftertreatment DEF dosing system to purge the DEF from the system. The DEF system purges to prevent damage from freezing. Failure to comply may result in equipment or property damage.



### WARNING

Turn off the engine and place the ignition switch in the OFF position before disconnecting the battery clamps. DO NOT place any tools or other materials on top of or close to the batteries. This

can cause a dangerous high current short circuit and, in the worst case, a battery explosion. Keep all objects away from the battery terminals. Always break the contact between the battery clamp and the negative terminal before working on the vehicle. Working on a vehicle while the battery is connected may result in electrical injury or damage. Always disconnect the battery at the negative terminal when performing service procedures. Failure to comply may result in death, personal injury or equipment damage.



### WARNING

Electrical shock hazard: Never disconnect the battery clamp when the engine is running. Disconnecting the battery clamps while the engine is running may result in death, personal injury or equipment damage from electrical arcing or damage to electrical components.

1. Disconnect the chassis battery cable at the negative battery terminal.



- Place an oil collection pan directly under the oil filter.

### Centrifugal Bypass Oil Filter Removal

Follow the procedure below after reading "Oil Filter Removal Preparation."



#### WARNING

Lubricating oil can cause skin irritation or skin injury. To prevent skin injury, avoid unnecessary contact with the lubricating oil. Wear protective clothing, eye wear, and gloves when handling lubricating oil. Failure to comply may result in personal injury.



#### CAUTION

Dirt in the engine oil lubrication system can lead to significant damage to the engine. Failure to comply may result in equipment or property damage.

Oil Filter Module

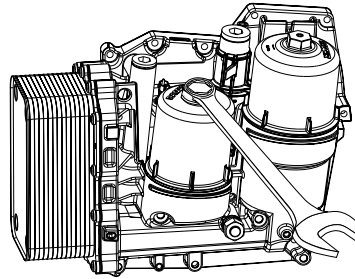

- Clean the oil filter cap and surrounding area to ensure dirt does not fall into the oil filter module.
- Remove the cap of the centrifugal oil filter. Use a hexagonal socket or a box wrench to avoid damaging the oil filter cap.
- Remove the centrifugal filter.
- Remove the O-ring from the screw cap.

### Centrifugal Bypass Oil Filter Installation

Follow the steps below to install the centrifugal bypass oil filter:

Centrifugal Bypass Oil Filter Installation

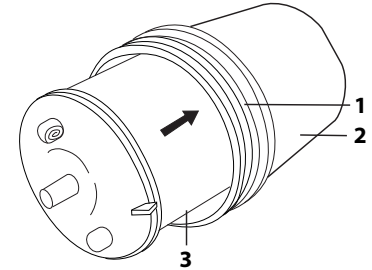

- Lightly lubricate the new O-ring (1) with clean engine oil.
- Fit the new O-ring (1) onto the cap (2).
- Mount the centrifugal filter (3) with its top side in the bearing of the screw cap (2).
- Check to ensure the centrifugal filter (3) can rotate freely.
- Position the screw cap carefully onto the oil module.
- Tighten the screw cap by hand until it reaches the end position.
- Tighten the screw cap to 65 Nm [575 lb-in]. Use a hexagonal

socket, or box wrench, to avoid damaging the oil filter cap.

### Full-flow Oil Filter Removal

Follow the procedure below after reading "Oil Filter Removal Preparation."

#### Full-flow Oil Filter Module

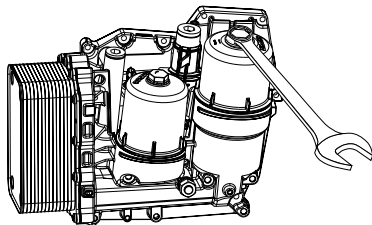

1. Unscrew the cap a few turns and drain the filter housing. Use a hexagonal socket, or box wrench, to avoid damaging the oil filter cap.
2. Remove the cap, with the oil filter cartridge, from the filter housing. Then remove the oil filter cartridge from the screw cap.
3. Remove the O-ring from the screw cap.



### WARNING

Lubricating oil can cause skin irritation or skin injury. To prevent skin injury, avoid unnecessary contact with the lubricating oil. Wear protective clothing, eye wear, and gloves when handling lubricating oil. Failure to comply may result in personal injury.

### Full-flow Oil Filter Installation



### NOTE

If the PACCAR part you are installing includes instructions or drawings that appear to conflict with this manual, follow the instructions included with the part. The instructions found with your part supersede this manual. Always refer to online service instructions for up-to-date service instructions.

Use the following procedure to install full-flow oil filters.

1. Check that all locking clips for the bypass valve are in place.
  - If one or more clips are missing, replace the filter screw cap.

2. Check the new O-ring for damage. If damaged, discard.
3. Sufficiently lubricate with engine oil:
  - The new O-ring
  - The O-ring groove in the filter cap
4. Install the new O-ring onto the filter cap using the installation sleeve. Do not twist the o-ring during installation.
5. Install the oil filter element into the filter cap.
6. Sufficiently oil all sealing surfaces and threads of the oil module.
7. Install the screw cap, with the oil filter cartridge, onto the filter housing. Tighten the screw cap to 70 Nm (354 lb-in). Use a hexagonal socket to avoid damaging the oil filter cap.

### After Replacing Engine Oil Filter(s)

Follow the steps below after installing new oil filters:

1. Reconnect the chassis battery cable at the negative battery terminal. See "Oil Filter Removal Preparation."
2. Add SAE-approved CK-4/CJ-4 engine oil to the maximum level

marked on the dipstick. If the engine is running a different weight of oil, be sure to top-off the engine oil with the same brand and viscosity of oil.

3. Make sure that all electrical components are switched OFF and the vehicle's transmission is in the neutral gear position before starting the engine.
4. Start and run the engine at idle speed for at least one minute to allow oil to reach all necessary components. Check for oil leaks.

**CAUTION**

Increasing the engine speed directly after maintenance or repairs to the lubrication system may cause damage to various engine components.

**CAUTION**

The red oil pressure warning in the instrument panel should disappear within ten seconds of the engine starting. If not, shut the engine OFF and investigate the problem. Failure to do so may

cause damage to various engine components.

5. Remove oil collection pan and dispose of any spillage properly.
6. Shut down the engine and allow at least 15 minutes for the oil to drain back into the oil pan. Check the oil level and top up as necessary. See "Engine Oil Level."

### Open Crankcase Ventilation (OCV) Module Maintenance

This emissions related component separates oil from air coming from the crank case vent. The unit sends the extracted oil back into the engine and provides clean vent air back into the air intake.

OCV

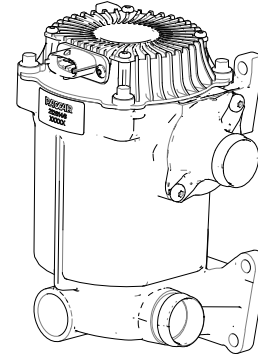

### How to Remove a Open Crankcase Ventilation Module

Follow the steps below to remove the OCV.

1. Disconnect the chassis battery cable at the negative battery terminal.
2. Place an oil collection pan directly under the OCV module.
3. Clean the OCV module and surrounding area to avoid dirt contaminating the module.



**NOTE**

Keep the new OCV module in its packaging until it's time to install it to the engine.

4. Disconnect the electrical connector and outlet hose.

**OCV - MX-13, Front**

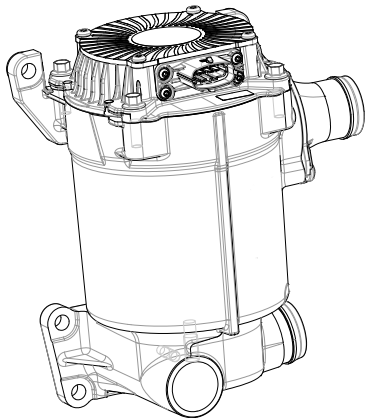

5. Remove the OCV module by unscrewing the six bolts using a ratchet with 13 mm socket.



**NOTE**

Be careful when removing the OCV to prevent an oil spill. Oil may be present in the OCV-to-engine interface.

6. Wipe the on-engine sealing surface with a clean, lint-free rag (not shown). Remove old face gasket.

**OCV - MX-13 Mounting**

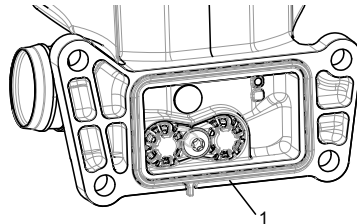

**How to Disassemble a OCV**

Ensure that you have followed these steps [How to Remove a Open Crankcase Ventilation Module](#) on page 73 before proceeding with disassembling the unit. Follow the steps below to disassemble the OCV to gain access to the replaceable filter and gaskets.

1. Lay the OCV module on a clean table with the engine interface facing down.
2. Unscrew the four bolts (1) using a ratchet with 10 mm socket.
3. Remove the motor from the housing and take out the filter.

**OCV Filter/Motor Installation**

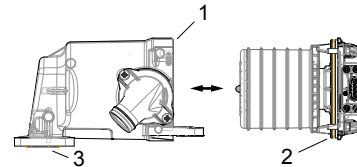

1. Housing
2. Motor
3. Mounting Flange

DO NOT remove the retaining ring e-clip from the shaft. The e-clip (1) being slanted is OK (2).

**OCV Retainer Ring Installation**

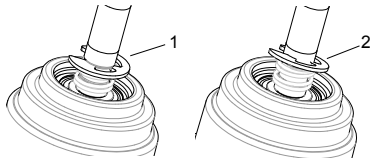

4. Remove the gasket from the motor as well as the gasket from the housing, and wipe the two gasket grooves with a clean, lint-free rag.
5. Properly dispose of the filter and gaskets.

**How to Reassemble a OCV Unit**

Follow the steps below to reassemble the OCV after the old filter and gaskets have been removed.

**OCV Motor/Filter Assembly**

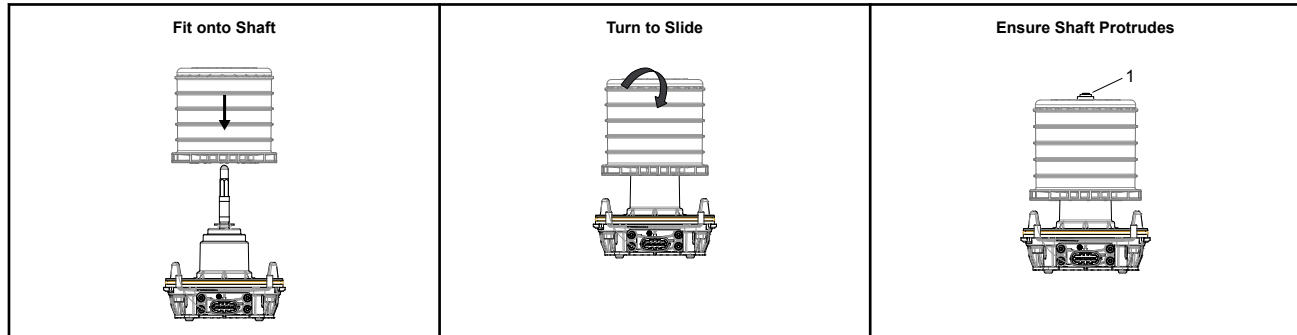

1. Install the new O-ring gasket on the motor and the new face gasket on the OCV-to-engine interface of the

OCV housing. Lubricate the two gaskets with clean engine oil.

2. Orient the motor so that the shaft is facing upward.

3. Take the new filter assembly out of its packaging, fit it on the shaft and turn it so that it slides into the notch and shaft protrudes through the end of the filter.
4. Install the motor with the new filter in the housing in horizontal position. When reinstalling motor, ensure shaft and bottom bearing are aligned (1).



**CAUTION**

Remove heavy items and secure any-DO NOT force motor into the OCV housing, or damage to the bottom bearing may occur.

5. Tighten and torque the four bolts (1) using a torque wrench to 70.8 lb-in.  $\pm$  8.4 (8.0 N·m  $\pm$  1.0).

OCV Filter/Motor Installation

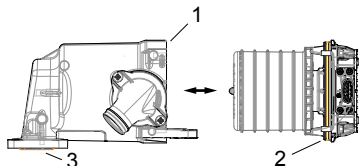

1. Housing
2. Motor
3. Mounting Flange

**How to Install a OCV Unit to the Engine**

Follow the steps below to install the OCV.

1. Install the OCV module on the engine. Tighten and torque the six bolts using a torque wrench to 16.2 lb-ft  $\pm$  1.5 (22.0 N·m  $\pm$  2.0).
2. Attach electrical connector and inlet/outlet hoses.

**Fuel Filter**

Perform these maintenance procedures according to the Preventative Maintenance Schedule.



**WARNING**

When removing the fuel filter, a quantity of fuel will escape. DO NOT smoke or allow an open flame in close proximity. Failure to do so could ignite a fire or cause an explosion which could result in serious injury to you and/or bystanders. Failure to comply may re-

sult in death, personal injury, equipment or property damage.



**CAUTION**

Replace fuel filters with parts of the same part number. PACCAR periodically changes its filter design, and filters of different part numbers are not interchangeable. Use of incorrect filter part numbers or non-genuine filters can result in low pressure fuel fault codes and/or severe engine damage. Contact a Kenworth or Peterbilt dealer to verify the correct fuel filter part numbers.



**NOTE**

The fuel filter and the hand pump are located on the left-hand side of the engine, as viewed from the driver's seat.



**NOTE**

Use of poor quality fuel may require more frequent fuel filter element service.

**Description**

The fuel filter/water separator module provides fine-particle filtration, water separation, water-in-fuel sensing, 12V preheating and system manual priming in a singular easy to service module.

**Biodiesel**

For information on alternative fuels, such as biodiesel, and additional information for fuel recommendations and specifications,

see [Warranty and the Use of Biodiesel Fuel](#) on page 65.

**Fuel Filter Removal (Primary and Secondary)**

Complete the following steps to remove the fuel filter(s):

1. Primary filter housing (cap installed)
2. Secondary filter housing (cap installed)
3. Priming pump handle

**Fuel Filter Module**

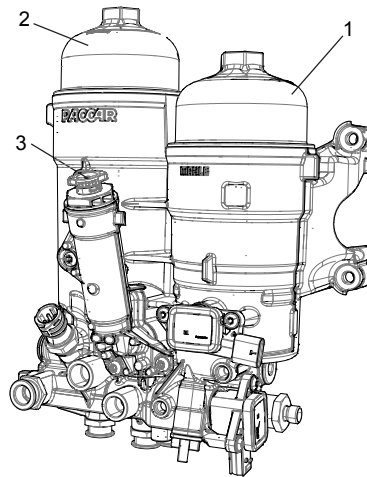

### Fuel Filter Module - Exploded

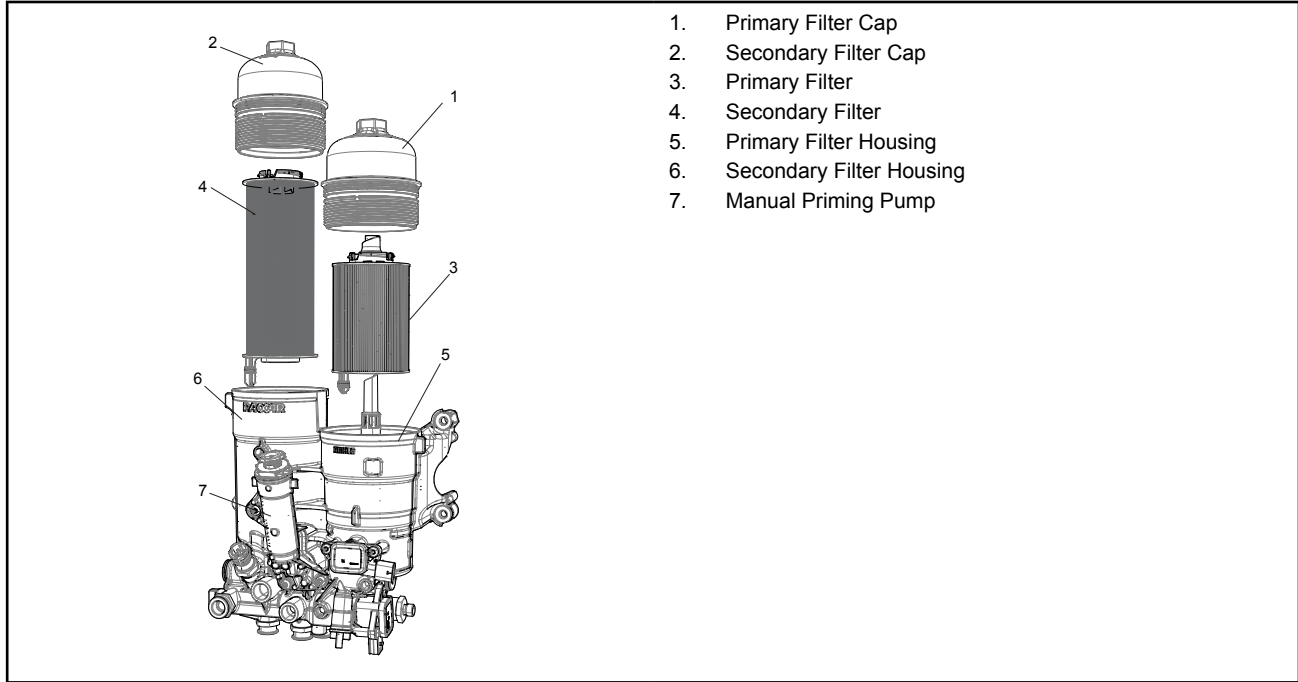



1. Clean the fuel filter cap and surrounding area with a clean rag to ensure dirt does not fall into the fuel module.

**CAUTION**

Dirt in the fuel system can lead to significant damage to the fuel system. Failure to comply may result in equipment or property damage.

**CAUTION**

Failure to prime any new (dry) fuel filter can cause severe engine damage due to dry starting the engine. Please refer to the priming procedure and follow it carefully after installing new filter cartridges and before starting the engine.

**CAUTION**

Complete draining is required to prevent cross contamination of dirty fuel into the clean side of the module dur-

ing new filter installation. Failure to do so may cause damage to the engine fuel system.

**NOTE**

The fuel filter cartridge is a disposable filter and must not be cleaned and reused. Dispose of the filter as chemical waste.

2. Loosen the fuel tank cap to relieve any pressure in the fuel tank.
3. Loosen primary fuel filter cap until O-Ring is visible.
4. Within 30 seconds, loosen secondary fuel filter cap until O-Ring is visible.
5. Wait 2 minutes for the fuel to completely drain to prevent fuel from leaking or dripping on the starter motor.
6. Remove fuel filter caps completely.
7. Remove fuel filter element from caps and discard. Keep caps.
8. Clean the fuel bowl and filter housing of any sediment or debris.

### Fuel Filter Installation (Primary and Secondary)

Follow the steps below to install new primary or secondary fuel filter:

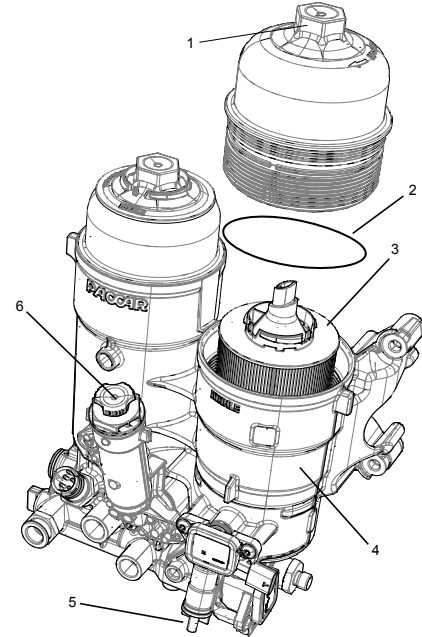

1. Verify the sealing O-Ring (2) supplied with the primary and

secondary fuel filter kit are installed on the fuel filter caps. Do not reuse old O-Rings.

2. Lightly coat the O-Rings with clean diesel fuel.
3. Install the primary and secondary fuel filter elements (3) into the caps.
4. Fill the housings (4) halfway with clean, filtered diesel fuel to aid in priming.
5. Reinstall the primary and secondary fuel filter caps (1) by rotating them clockwise until the O-Rings on the caps make contact with the housing.
6. Tighten the caps to 30 lb-ft +/- 6 (40 Nm +/-8), as specified on the caps.
7. Bleed the fuel system thoroughly using the hand primer pump (6).
8. See "Priming the Fuel System" and follow the procedure carefully. Note that this will include starting the engine.
9. Install the fuel tank filler cap.



**NOTE**

Make sure that the diesel fuel and your hands are clean.



**NOTE**

Part number (5) is the water drain spigot used in the Water Draining Procedure.



**NOTE**

Depending on the vehicle's fuel system configuration the fuel filter housing may not completely drain of fuel. If this is the case, take care when installing the new filter as this may cause fuel to spill from the filter housing.

**Priming the Fuel System**

To start the engine after the fuel tank has run dry, or after the fuel system service has been performed, complete the following steps:



**CAUTION**

The following instructions should be used in emergency situations when the fuel tank has run dry, or after the fuel system service has been performed. Failure to follow the starting instructions below may damage the starter motor.

Fuel Filter Module, Priming Pump - MX-13

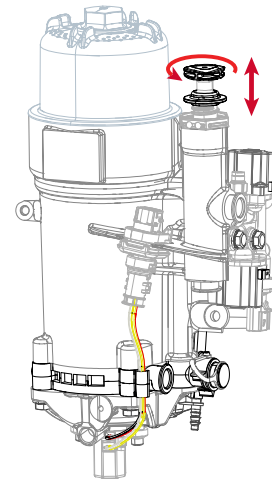

1. Loosen the fuel primer pump knob by rotating it counter-clockwise.
2. Operate the priming pump by moving the knob in and out for 150 seconds. During this time the pumping resistance will increase, indicating air is being bled from the system, but the full time is required to fully prime the fuel system.

 **CAUTION**

Operate priming pump at a maximum rate of 30 strokes per minute to prevent damage to pump.

3. Check for leakage at the fuel filter cap. Tighten if necessary.

 **WARNING**

Check the fuel filter for signs of leakage. DO NOT smoke or allow an open flame in close proximity. Failure to do so could ignite a fire or cause an explosion which could result in serious injury to you and/or bystanders. Failure to comply may result in death, per-

sonal injury, equipment or property damage.

4. Start the engine and allow it to idle for 2 to 3 minutes. Note that it could take up to 15 seconds of cranking for the engine to start. If the starter is engaged for longer than 20 seconds without starting, additional priming pump actuation may be necessary.

 **CAUTION**

If the engine is cranked excessively Starter Protection will be triggered and starter engagement will be restricted for 10 minutes.

5. Check the system for leakage while idling. Then turn the engine OFF and check the system again for leakage.
6. If the engine does not start within this time, repeat steps two and three until the engine starts. If the engine still does not start, allow the starter to cool down for at least 5 minutes before repeating the procedure.

 **WARNING**

DO NOT loosen any fuel line fittings in order to bleed the fuel system of air. The system is under high pressure which, when relieved, could cause death, personal injury, equipment or property damage.

### Fuel Filter Water Draining Procedure

Wear fuel-safe gloves. Have a one liter or larger jar or can available, and a place to responsibly dispose of contaminated water. Follow the steps below to drain water from your primary fuel filter housing.

1. Locate the drain spigot on the bottom of the filter housing. The spigot is a quarter-turn valve, no tools are required to open it.
2. Place a can, or preferably, a transparent jar, below the drain to catch the fuel/water mix that will come out.
3. While watching the drain, open the spigot allowing any water that may be in the filter housing to come out. If water is present, it should exit the housing before any fuel.

4. When no more water comes out, close the drain.
5. Discard of the waste fuel/water appropriately.

### Cooling System

Your engine may be equipped with a coolant filter designed to capture and remove harmful deposits from the cooling system to help prolong system life. Refer to the Preventative Maintenance Schedule for the recommended coolant filter change service interval.



#### WARNING

Do not remove the surge tank fill cap on a hot engine. It can cause scalding coolant to spray out and you could be burned. If the engine has been operated within the last 30 minutes, be very careful in removing the radiator cap. Protect face, hands, and arms against escaping fluid and steam by covering the cap with a large, thick rag. Failure to comply may result in death, personal injury, equipment or property damage



#### WARNING

Handle coolant and antifreeze carefully. Ethylene glycol antifreeze is poisonous. Store in original fluid container only, and always keep out of the reach of children. Never remove the filler cap (vertically mounted) on the surge tank while the engine is still hot. Wait until the coolant temperature is below 120°F (50°C). Scalding steam and fluid under pressure may escape and cause serious personal injuries. The pressure cap (horizontally mounted) on the surge tank should never be opened. Failure to comply may result in death, personal injury, equipment or property damage.

### Coolant/Antifreeze Condition

Perform these maintenance procedures according to the Preventative Maintenance Schedule.



#### NOTE

Test the engine coolant at least twice per year to determine if the coolant must be replaced. If it is determined that the coolant should be replaced, make sure to flush the coolant system. Contact a PACCAR® Authorized Repair Location for flushing the coolant system.

1. Check the following anti-freeze conditions:
  - Coolant level
  - Freeze point
  - pH level
  - Nitrite level
  - Carboxylate level

### Checking Coolant Condition

To ensure the Extended Life Coolant (ELC) in your vehicle always provides maximum protection, perform the following tests:

1. Check the coolant color at every maintenance interval. It should have no cloudiness, floating debris, or oils.

2. Test the freeze point at least twice a year. A refractometer or test strips can be used to measure the protection level.
3. Determine the pH and chemical inhibitor concentration level by using an ELC-specific test kit or test strips.
4. Keep the cooling system full by topping-up using ELC pre-diluted to a 50/50 blend, unless a different ratio of water/antifreeze has been substituted (depending on operating conditions).

test kits, test strips, and laboratory sample procedures.

**Radiator Hoses**

Perform these maintenance procedures according to the Preventative Maintenance Schedule.

1. Check the following radiator hose conditions:
  - Deterioration/signs of leaking
  - Hose clamp torque

**Replace Coolant Filter**

Perform these maintenance procedures according to the Preventative Maintenance Schedule.

Coolant Shutoff Valve

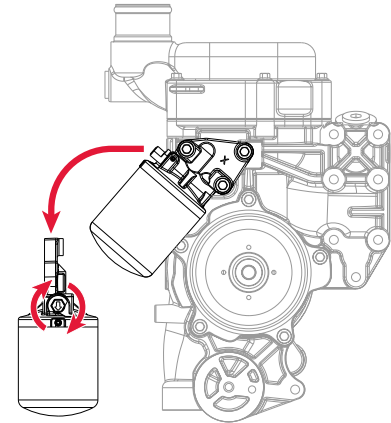

1. Slowly loosen the radiator cap to relieve any pressure in the cooling system.
2. Close the coolant filter shutoff valve by rotating the hex key clockwise and away from the "O" position.
3. Clean the coolant filter and surrounding area.
4. A small amount of coolant could leak out when the filter is loosened.

**i** NOTE

Inhibitor concentration level determines corrosion protection. If you are concerned about possible coolant quality, contamination, or mechanical problems, submit a coolant sample to your dealer for analysis. Improper maintenance may cause coolant degradation and could result in damage to the cooling system and engine components. Consult your dealer or the coolant manufacturer's representative for recommended extended life coolant

Use a suitable container to catch any coolant.

- Remove the coolant filter by rotating it counter-clockwise. Use a filter wrench to remove.



**NOTE**

The coolant filter cartridge is a disposable filter and may not be cleaned and reused. Dispose of the filter as chemical waste.

- Remove the O-ring from the coolant filter housing, if it has not been removed already.

**Coolant Filter Removal**

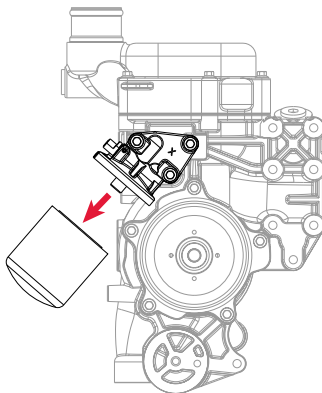

**Coolant Filter Installation**

Follow the steps below to install the engine coolant filter:

- Apply a small amount of coolant to the sealing ring of the new coolant filter.
- Install the filter, rotating it clockwise until the sealing ring makes contact with the filter housing. Then tighten by hand 1/2 - 3/4 of a turn.
- Turn the shutoff valve to the OPEN position.

- Reinstall the radiator fill cap.
- Start the engine and run at idle speed for several minutes. Check for leaks.

**Special Fill Instruction**



**CAUTION**

Follow the procedure below to fill coolant. Failure to follow this procedure and maintain proper coolant level can cause engine damage.

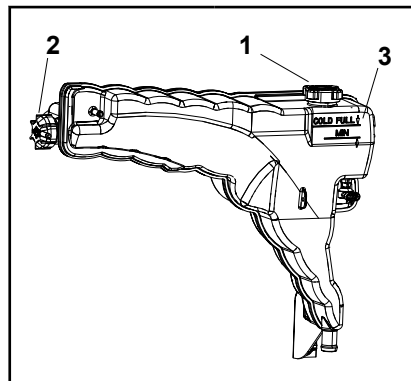

1. Fill cap (service point)
2. Pressure cap (never to be removed)
3. Fill line

1. Remove the Fill Cap (1) (Do not remove the surge tank pressure cap)(2).
2. Fill the system with premixed coolant to the surge tank full cold line.
3. Start the engine and idle at low RPM for 2 min.

4. Top-off surge tank to full cold line while idling.
5. Run engine at higher idle until engine fan turns on and allow thermostat to open.
6. Reduce idle to low RPM and top-off surge tank full cold line.
7. Run Engine at higher idle for 10 min.
8. Reduce idle to Low RPM and top-off surge tank to full cold line.
9. \*\*Allow engine to cool and top-off surge tank full cold line if necessary.
10. Replace the Fill Cap
11. \*\*If Low Coolant Alarm is consistently triggering, allow engine

to cool to outside air temperature , then top off surge tank to full cold line.

	NOTE
<p>If the coolant frequently needs top-ping-up or there are any signs of coolant leakage, consult a PACCAR Service dealer.</p>	

**Drive Belts**

2

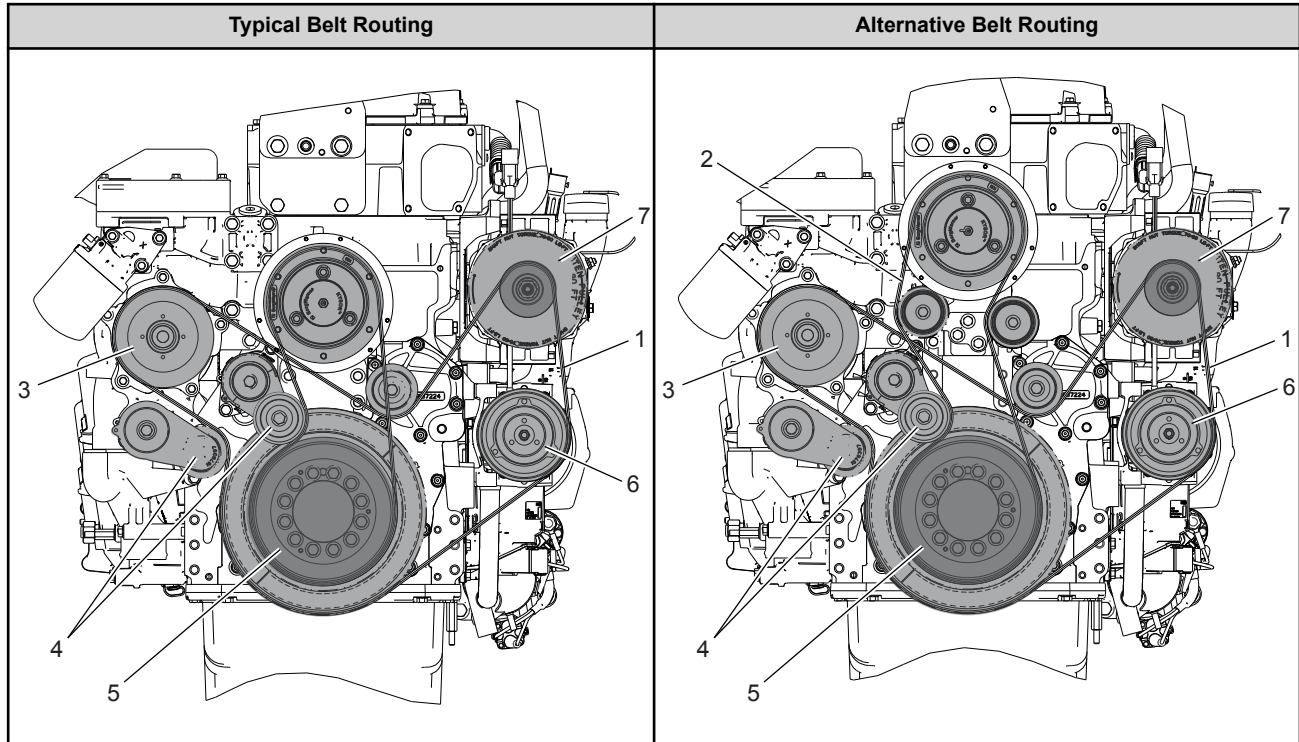



1. Accessory belt
2. Fan belt (No fan belt with T680MLU MX-11 and LHP MX-13).
3. Water pump
4. Tensioners
5. Engine dampener
6. A/C compressor
7. Alternator

 <b>NOTE</b>
Always fit the same type of belts as the ones replaced.

### Engine Belt Checks

Perform these maintenance procedures according to the Preventative Maintenance Schedule.

1. Inspect the engine drive belts for the following conditions:
  - Condition, signs of wear/deterioration
  - Alignment

### Fan Belt Tensioner (If So Equipped)

 <b>NOTE</b>
No fan belt with T680MLU MX-11 and LHP MX-13.

Perform these maintenance procedures according to the Preventative Maintenance Schedule.

1. Check and correct fan belt tensioner.
  - Mounting bolt torque
  - Tensioner maintains proper belt tension

### Engine Fan

 <b>WARNING</b>
DO NOT work on or near the fan with the engine running. Anyone near the engine fan when it turns on could be injured. If it is set at MANUAL, the fan will turn on any time the ignition key switch is turned to the ON position. In AUTO, it could engage suddenly without warning. Before turning on the igni-

tion or switching from AUTO to MANUAL, be sure no workers are near the fan. Failure to comply may result in death or personal injury.
---

Follow these guidelines to check your engine fan:

- With the engine shut off, check the fan hub bearings for looseness, loss of lubricant, and any abnormal conditions (e.g. fan belt misaligned or excessive wear/damage, etc.).
- With the engine idling and the hood open, stand at the front of the vehicle. Listen for any noises coming from the fan hub. Bearings that have lost lubricant and are dry will typically emit a squeal or a growl when the engine is at operating temperature and the fan clutch is engaged. If noise is detected, have the fan bearings inspected by an authorized dealership.

### Engine Fan Blade

Verify that there is enough fan blade clearance with the fan shroud. The recommended distance around the fan shroud is 1 in. (25 mm) from front edge of

any fan blade-to-radiator side member. Minimum clearance is 3/4 in. (19 mm).

- Rear edge of any blade must be no closer than 3/8 in. (9 mm) to the nearest engine component. If this cannot be obtained, the fan spacer or fan is incorrectly placed.
- The leading edge of any fan blade must be 1 in. (25 mm) from the inside edge of the shroud.

### Crank Mounted Fan Belt Routing

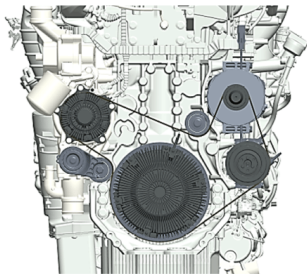

If your vehicle is equipped with a crank mounted fan you will have only one, poly v-belt as depicted here. The belt seen in this image does not drive the fan. Note that crank mounted fans still utilize some

variation of clutch, or variable speed apparatus.

### Poly V-belt and Fan Drive Belt Removal

Perform these maintenance procedures according to the Preventative Maintenance Schedule.

1. Disconnect the electrical ground wire from the battery.
2. Reach between the fan blades and remove the fan blade mounting bolts using a 9/16 in. socket to remove the mounting nuts.
3. Place a flex-bar with a 15 mm socket on the fastener securing the automatic belt tensioner's roller, as shown in the image.

Flex Bar on Tensioner - V-belt and Fan Drive Belt

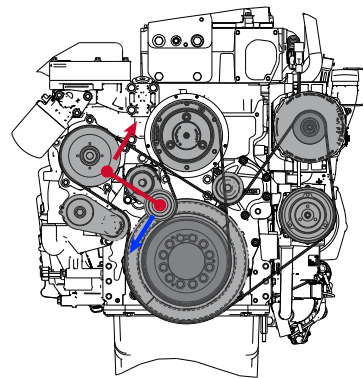

4. Rotate the flex-bar as shown in the diagram to relieve belt tension.
5. With the belt tensioner pressure relieved, remove the poly V-belt from the pulleys.
  - The tensioner can be temporarily blocked with a 0.16-0.2 in. (4-5 mm) thick pin (bore). This facilitates removal and installation of the poly V-belt.
6. After removing the belt, carefully allow the belt tensioner to spring

back to the stop (if it had not been temporarily blocked).

7. Inspect the pulleys for damage, rust, and grease deposits. Clean or replace as necessary.

**Poly V-belt and Fan Drive Belt Installation**

Follow the steps below to install the poly V-belt and fan drive belts:

 <b>NOTE</b>
No fan belt with T680MLU MX-11 and LHP MX-13.

1. Place the new poly V-belt over the pulleys, making certain the belt falls into all the belt pulley grooves.

 <b>NOTE</b>
When installing the belts DO NOT wrap belt around the tensioner until after the belt has been wrapped around all other pulleys and idlers.

2. After installing the belt, carefully allow the belt tensioner to spring back to its normal position. If the

tensioner had been temporarily blocked, relieve tensioner pressure enough to remove the locking pin, then allow the tensioner to spring back to its normal position.

 <b>NOTE</b>
DO NOT reuse nylon patch lock nuts. Replace with new lock nuts when reinstalling parts.

3. Reinstall fan blade using NEW 5/16-18 UNC-2A on Horton fans, or 3/8-24UNF-2A on BorgWarner fans, with nylon patch lock nuts.
4. Reconnect the electrical ground wire to the battery.

**Poly V-belt, Alternator, Air-Conditioning Compressor Drive and Coolant Pump Drive Removal**

Follow the steps below to remove the poly V-belt, alternator, air-conditioning compressor drive and coolant pump drive belts:

1. Remove the poly V-belt from the fan and coolant pump drive as described in "Poly V-belt and Fan Drive Belt Removal."

 <b>NOTE</b>
Removing the fan blade is not necessary if only the accessory belt is removed. After removing the fan drive belt from its pulleys the accessory belt can be removed over the fan blade.

2. Next, place a flex-bar with a 15 mm socket on the alternator and air conditioning compressor drive belt tensioner roller fastener as shown. Move the bar in the direction

shown to relieve pressure on the belt tensioner.

**Flex Bar on Tensioner - Compressor and Coolant Pump Belt**

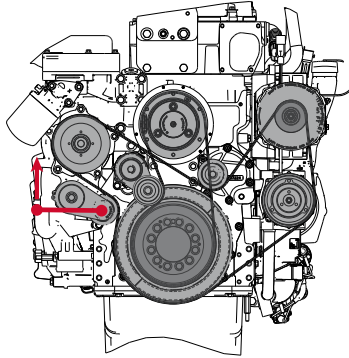

3. With the belt tensioner pressure relieved, remove the poly V-belt from the pulleys.
  - The tensioner can be temporarily blocked with a 0.16-0.2 inch (4-5 mm) thick pin (bore). This facilitates removal and installation of the poly V-belt.

4. After removing the belt, carefully allow the belt tensioner to spring back to the stop (if it had not been temporarily blocked).
5. Inspect the pulleys for damage, rust and grease deposits. Clean or replace as necessary.

**Poly V-belt, Alternator, Air-Conditioning Compressor Drive and Coolant Pump Drive Install**

Follow the steps below to install the poly V-belt, alternator, air-conditioning compressor drive and coolant pump drive belts:

1. Place the new poly V-belt over the pulleys, positioning the new belt so that it falls into all the belt pulley grooves.



**NOTE**

When installing the belts DO NOT wrap belt around the tensioner until after the belt has been wrapped around all other pulleys and idlers.

2. After installing the belt, carefully allow the belt tensioner to spring back to its normal position. If the tensioner had been temporarily blocked, relieve tensioner pressure

enough to remove the locking pin, then allow the tensioner to spring back to its normal position.

3. Reinstall the fan drive poly V-belt as previously described in [Poly V-belt and Fan Drive Belt Installation](#) on page 89.
4. Reconnect the electrical ground wire to the battery.

**Aftertreatment System**

**Diesel Particulate Filter (DPF) Service Strategy**

There are two DPF cleaning strategy options; dry cleaning and wet cleaning. Some chassis can follow either strategy but only one strategy may be used. They are not interchangeable. It is the vehicle owner's responsibility to choose one of the two options and maintain the DPF using that one strategy. The wet cleaning service interval is twice as long as the dry cleaning interval. Both strategies are shown on the Preventative Maintenance Schedule.

 NOTE  
DO NOT switch from one cleaning strategy to the other. Doing so may void your warranty.

 NOTE  
The DPF dry clean/wet clean intervals are based on the use of lubricating oils

that meet the SAE 10W-30 API CK-4/CJ-4 oil specification.

1. Dry Cleaning strategy - Normal Duty/Line Haul may use this strategy; however, Severe Duty/Vocational applications must only use the dry cleaning strategy. Dry cleaning can be performed at an authorized PACCAR dealer. Replace filter if necessary.
2. Wet Cleaning strategy - Only Normal Duty/Line Haul may use

this strategy. A wet cleaned filter is one that has been cleaned to PACCAR specifications using advanced liquid cleaning technology. Wet cleaned filters can only be purchased from PACCAR Parts and are designated with a "PRX" suffix. See your authorized PACCAR dealer.

**Diesel Exhaust Fluid (DEF) Filter**  
Perform these maintenance procedures according to the Preventative Maintenance Schedule.

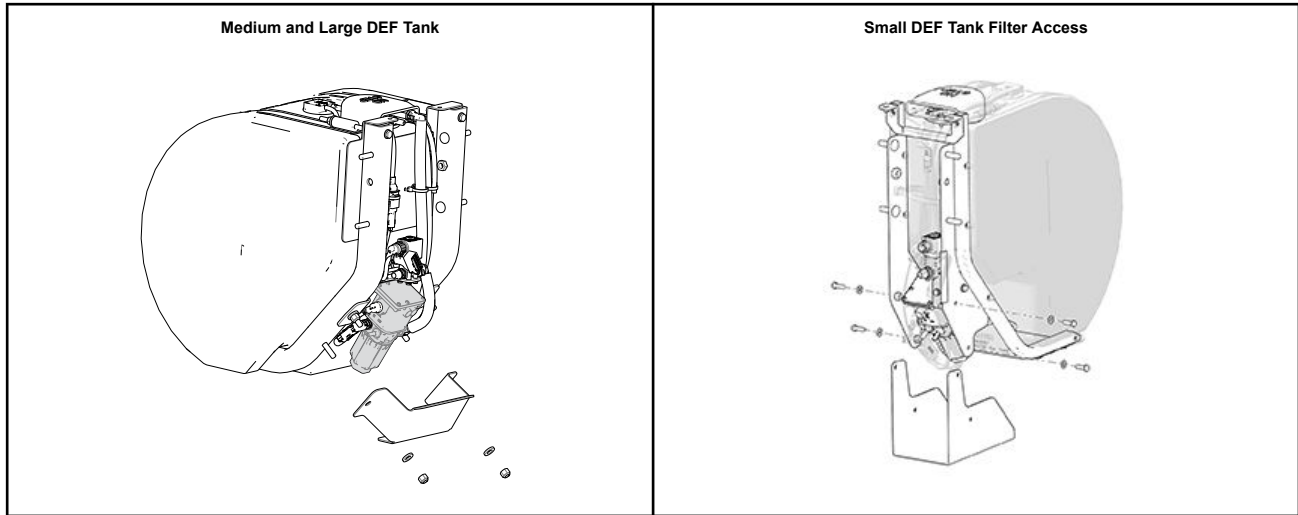

1. Replace the aftertreatment DEF dosing unit (DEF module) filter according to the maintenance schedule.
2. From the bottom of the tank, remove the cover plate by removing the various fasteners holding it on, then allow the cover plate to drop down.

### Air System

#### Air Intake System

Engine heat, vibration, and age combine to loosen air intake connections and cause cracks in the tubing and elbows. Leaks in the intake system allow abrasive dust to enter the engine and quickly cause expensive damage. During your daily walk-

around inspection, carefully check all tubing, elbows, clamps, supports, and fasteners for condition and tightness. Check the charge-air-cooler for air leaks annually. The air leaks can be caused by cracked tubes or header. For service see your authorized dealer.

 **CAUTION**

DO NOT use air intake pipes and connections as a step or to pull yourself up. This could loosen the connections and open the system to unfiltered air which could damage the engine.

**Air Compressor**

Perform these maintenance procedures according to the Preventative Maintenance Schedule.

1. Check and correct for carbon buildup

**Charge Air Piping**

Perform these maintenance procedures according to the Preventative Maintenance Schedule.

1. Check and correct the following charge air piping components:
  - Hose/pipe condition – deterioration/signs of leaking
  - Hose clamps for tightness
  - Clearance to other components

**Charge Air Cooler**

Perform these maintenance procedures according to the Preventative Maintenance Schedule.

1. Check and correct the following components of the charge air cooler:
  - Cracked tubes or header
  - Clogged fins/tubes
  - Hose/pipe condition – deterioration/signs of leaking
  - Hose clamp torque

**Engine Air Filters**

The following service information is basic to all engine air filter makes and models.

 **WARNING**

DO NOT use air filter housings as grab handles. These components may break if you are using them to support your weight. Failure to comply may result in personal injury or damage to vehicle components.

 **WARNING**

DO NOT push on the under hood air door with hands. This door is held closed with a spring which may shut close unexpectedly. Failure to comply may result in personal injury.

 **CAUTION**

Failure to replace air filter at proper intervals may result in passage of dirt/debris into the engine or the “dusting” of an engine resulting in significant equipment damage.

Your vehicle is equipped with an air inlet restriction indicator as standard equipment on the air filter housing (an in-cab restriction gauge is optional in some models). Service the filter elements when the air inlet restriction indicator indicates that service is needed. Paper elements require care and proper handling because they are critical to engine service life. The engine air filter is located on the top of the engine just below the hood. There are

four fasteners that hold the cover to the filter housing.  
If the vehicle has the under hood air intake option, the air intake solenoid and the airline may need to be removed to access the air filter.



**NOTE**

Be sure to check your vehicle for an ember pack or pre-cleaner filter when servicing the engine air filter.

Perform the following maintenance procedures according to the Preventative Maintenance Schedule.

Check and correct for restriction:

- Service air filter element when air inlet restriction gauge indicates service is needed
- Check hose/pipe condition – deterioration/signs of leaking
- Check hose clamp torque

**Replace Engine Air Filter**

If the vehicle is equipped with Cab mounted air cleaner and under hood air intake option, remove the air solenoid first..

1. Park the vehicle. Set the parking brake and turn the ignition OFF.

2. If the air cleaner is under the hood, open the hood to access the air filter housing.
3. Loosen the hardware that holds the housing cap to the main filter enclosure.
4. Pull the air filter housing cap away from the main enclosure to access the filter.
5. Visually inspect the filter housing, enclosure, and hardware for damage.
6. The filter can be removed by gently pulling it directly out of the main enclosure. Be careful not to drop or tap the filter on the housing during removal as this could loosen dirt and dust trapped in the filter. DO NOT clean or reuse the original filter.
7. Inspect the sealing surfaces and clean out any debris from the inside of the filter enclosure before installing the new filter. Be careful to not push any contaminant into the engine inlet.
8. Visually inspect the new filter prior to installation. There should not be any damage to the filter media or

gaskets, such as dents, dings, cracks, or holes.

9. After installing the filter, inspect for a good seal, if possible.
10. Install the filter housing cap and tighten the hardware. DO NOT use the housing cap to drive the filter into position.
11. Start the engine and allow the air system to reach operating pressure. Activate the under hood air switch and verify that there are no air leaks.

**Air Filter Restriction Indicator (Option)**

An Air Filter Restriction Indicator may be installed on the air filter housing or air induction piping for access to clean, filtered air.

As the filter plugs and restriction increases, a red indicator will appear in a window on the indicator. When red appears, the air filter should be replaced. The indicator can be reset by pressing the button at the end of the indicator.



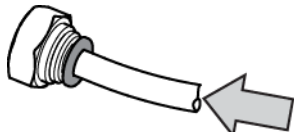
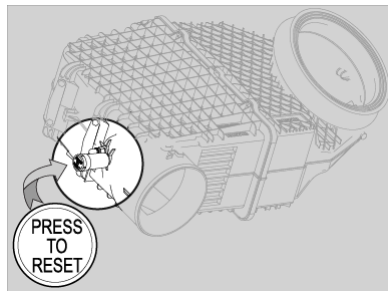

PUSH  
(EMPUJAR;  
POUSSER)

### Turbocharger



#### WARNING

DO NOT operate engine with turbocharger intake piping disconnected. A suction is created when the engine is running. This suction could draw your

hand or anything else near it into the impeller fan. You could be injured. Always keep the intake piping connected when you will be running the engine.

When servicing the air intake and exhaust systems on a turbocharged engine, check the items listed below:

### Lubricating System

Check the oil lines, housing, and connections. Look for leaks, damage, or deterioration. Leaks could mean you have damaged oil lines or oil seals.

### Manifold

With the engine operating, check for leaking manifold or flange gaskets.

### High Frequency Vibration

Vibration may indicate turbo rotor imbalance. Have your dealer investigate this immediately. If you detect any deficiencies, take the vehicle to an authorized dealer for servicing. Delay could lead to severe and expensive damage to your vehicle.

### Exhaust System

The exhaust system is part of the noise and emission control system. Periodically check the exhaust system for wear, exhaust leaks, and loose or missing parts. For details on how to maintain the emissions components in the exhaust system, see "Noise and Emission Control" in your vehicle operator's manual. Please refer to the engine operator's manual for more details on how to maintain the emissions components in the exhaust system.

### Charging - Cranking System

#### Electrical Harness / Cables

Perform these maintenance procedures according to the Preventative Maintenance Schedule.

1. Check the following electrical components:
  - Inspect for loose connections, corrosion, chafing, and broken retention clips

#### Batteries, Cables, and Connections

Perform these maintenance procedures according to the Preventative Maintenance Schedule.

1. Check the following electrical components:
  - Condition – electrolyte level, cracks, signs of leaking, overcharging
  - Hold-downs – tightness
  - Battery box mounting bolt – torque

**Crankshaft - Vibration Damper**

Perform these maintenance procedures according to the Preventative Maintenance Schedule.

1. Inspect for cracks, nicks, or other physical damage.
2. Inspect for loose or missing fasteners.
3. For rubber dampers, inspect for damage to the rubber ring.
4. For viscous dampers, inspect for leaks.

**Engine Mounting Bolts**

Perform these maintenance procedures according to the Preventative Maintenance Schedule. Check for the following:

1. Inspect both mount and leg fasteners. Check for loose or broken bolts. Replace as necessary.
2. Check mount and leg for fractures, breaks or deformation. Replace as necessary.
3. Check for complete insertion of motor mount. Replace as necessary.



**CAUTION**

DO NOT re-torque or reuse existing flange head bolts. These bolts are factory set to the specified torque. If bolts are loose or damaged, they must be

replaced with the new bolts. Failure to comply may result in equipment or property damage.

**Engine Valves**



**NOTE**

Adjusting your engines valves is a complex task that requires specialized tools and training. Please inquire with an authorized PACCAR dealer or service provider about this procedure.

Have the valve clearance maintenance procedures done according to the following intervals.

**Engine Valve Adjust Intervals**

	<b>Vehicle Application</b>	<b>Interval</b>
Valve Adjust Interval	Normal Duty (Line Haul) - less than 20% idle time	Initial adjust at 150,000 mi (240,000 km, 6,750 hours), at 450,000 mi (725,000 km, 13,500 hours), then every 300,000 mi (480,000 km) thereafter
	Normal Duty (Line Haul) - more than 20% idle time	
	Severe Duty (Vocational) <sup>39</sup>	Initial adjust at 60,000 mi (96,000 km, 1,600 hours), at 360,000 mi (576,000 km, 9,600 hours), then every 300,000 mi (480,000 km) thereafter
	Pick-up/Delivery/Refuse	

**Engine Identification**

**Component Locations**

<sup>39</sup> Vocational vehicle applications include: Agriculture, Concrete Mixers, Construction, Crane, Dumps, Emergency/Fire, Heavy Equipment, Loggers, Mining, Oil Field, Snowplows, and Wrecker.

2

**Engine - Right Side**

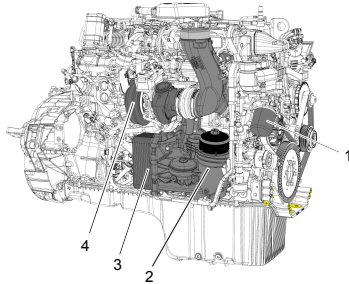

1. Coolant filter
2. Full-flow oil filter
3. Centrifugal bypass oil filter
4. Oil cooler
5. Turbocharger

**Engine - Left Side**

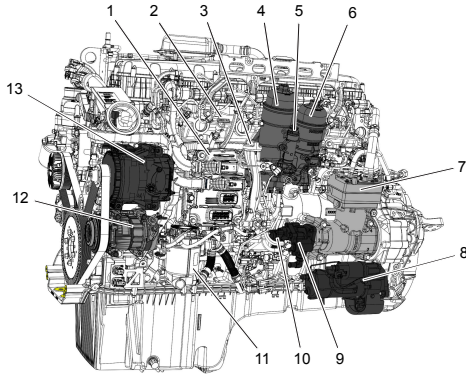

1. Oil fill
2. Fuel filter
3. Air compressor
4. Starter
5. Power steering pump
6. Low pressure fuel pump
7. Electronic control module (ECM)
8. Open Crankcase Ventilation module
9. A/C compressor
10. Alternator
11. Dipstick

**EPA Label**

The EPA label provides important facts about the engine. This label is located on

top of the engine valve cover or on the mixer manifold. The engine EPA label must not be changed unless approved by PACCAR.

**PACCAR MX EPA Label Location**

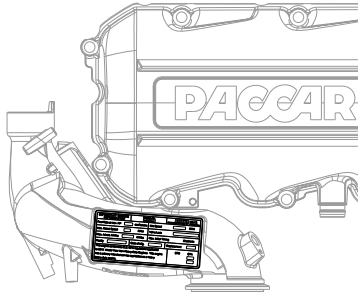

The EPA label provides many details regarding the engine. Some facts that are found on the EPA label include the following:

- Fuel rate
- Idle speed
- Maximum rated speed
- Valve lash
- Maximum power rating
- Date of manufacture
- Engine displacement

**PACCAR MX EPA Label**

<b>IMPORTANT ENGINE INFORMATION</b>		Engine No.		<b>PACCAR MX-</b> MANUFACTURED BY HINO	
Fuel Rate at Adv. HP	XXXX mm <sup>3</sup> /stroke	Idle Speed	XXX-XXX	RPM	
Max. Rated Speed	XXXX RPM	Valve Lash (mm)	X.XX Int.	X.XX exh.	
Max. Advert. kW/hp	XXXXXX kW/hp	Max. Initial Timing	Electronic		
Family	EPCR112.9M01	Date of Mfg.	Displacement	12.9 L.	
This engine conforms to U.S. EPA regulations and is applicable to 2014 Model Year New Heavy-Duty Engines. This Engine has a primary intended service application as a heavy heavy-duty engine. This engine is certified to operate on ultra-low sulfur diesel fuel only. Exhaust Emission Control System: DDI, TC, CAC, ECM, EGR-C, DC, SCR-U, PTOX			STD	EPA	
			N0x	X.XX	
			PM	X.XX	
			1952313		



## Chapter 3 | INFORMATION

United States and Canada Engine Warranty..... 103



## United States and Canada Engine Warranty

### Engine Warranty for Standard Applications

#### Products Warranted

This warranty applies to new PACCAR MX-13 engines sold and used in the United States<sup>40</sup> or Canada and operated in on-highway applications with one exception – there is different warranty coverage for engines used in the fire apparatus truck applications.

The PACCAR MX-13 engine is warranted directly to the first purchaser or first lessee by PACCAR.

#### Base Engine Warranty

This warranty covers any failures of the engine which result, under normal use and service, from a defect in material or factory workmanship (warrantable failure). This coverage begins on the date of delivery and ends two years or 250,000 miles

(400,000 kilometers) or 6,250 hours, whichever occurs first, after the date of delivery of the engine to the first purchaser or first lessee.

Additional coverage is outlined in [Emissions Warranty](#) on page 108.

#### Major Engine Components Warranty

There is an Engine Warranty period of 60 months, 500,000 miles (800,000 kilometers) or 12,500 hours, whichever occurs first, after the date of delivery of the engine to the first purchaser or first lessee for the following engine parts:

- Cam Follower Assemblies
- Camshaft
- Camshaft Gear
- Camshaft Idler Gear
- Connecting Rod Assemblies
- Crankshaft
- Crankshaft Gear
- Cylinder Block Casting
- Cylinder Head Bolts
- Cylinder Head Casting
- Flywheel Housing

- Lube Pump Gear
- Main Bearing Bolts
- Thermostat Housing
- Water Pump Housing

### PACCAR and Owner Responsibilities

#### PACCAR Responsibilities

PACCAR will pay for all parts and labor needed to repair the damage to the engine resulting from a warrantable failure.

PACCAR will pay for the lubricating oil, antifreeze, filter elements, belts, hoses, and other maintenance items that are not reusable due to the warrantable failure. PACCAR will pay for reasonable labor costs for engine removal and reinstallation when necessary to repair a warrantable failure.

PACCAR will pay during the base engine warranty period of two years or 250,000 miles (400,000 kilometers) or 6,250 hours, whichever occurs first: reasonable costs for towing a vehicle disabled by a warrantable failure to the nearest authorized repair location. In lieu of the towing expense and

<sup>40</sup> United States includes American Samoa, the Commonwealth of Northern Mariana Islands, Guam, Puerto Rico, and the U.S. Virgin Islands.

in its sole discretion, PACCAR may pay reasonable costs for a mechanic to travel to and from the location of the vehicle when an engine repair is performed at the site of the failure.

### **Owner Responsibilities**

The owner is responsible for the operation and maintenance of the engine as specified in the applicable PACCAR Operator's Manual. The owner is also responsible for providing proof that all recommended maintenance has been performed.

Before the expiration of the applicable warranty, the owner must notify a PACCAR authorized engine dealer of any warrantable failure and make the engine available for repair by such facility. The warrantable failure must be brought to the attention of a PACCAR authorized engine dealer within 30 days of discovery. Except for engines disabled by a warrantable failure, owner must also deliver the engine to the repair facility.

The owner is responsible for the cost of lubricating oil, antifreeze, filter elements and other maintenance items provided during warranty repairs unless such items are not reusable due to the warrantable failure. The owner is responsible for

communication expenses, meals, lodging and similar costs incurred as a result of a warrantable failure.

The owner is responsible for non-engine repairs and for "downtime" expenses, cargo damage, fines, all applicable taxes, all business costs and other losses resulting from a warrantable failure.

The owner is responsible for non-engine repairs and for "downtime" expenses, cargo damage, fines, all applicable taxes, all business costs and other losses resulting from a warrantable failure.

### **Warranty Limitations - Standard Applications**

Your sole and exclusive remedy against PACCAR and the selling dealer arising from your purchase and use of this engine is limited to the repair or replacement of "warrantable failures" at authorized United States and Canadian PACCAR engine dealers, or an authorized PACCAR engine facility where applicable, subject to PACCAR's time, mileage, and hour limitations of the engine warranty. The maximum time, mileage and hour limitations of the engine warranty begin running on the date of delivery to the first purchaser or first lessee. The accrued time, mileage, or hours is calculated when

the engine is brought into an authorized dealer for correction of warrantable failures.

Failures, other than those resulting from defects in material or factory workmanship, are not covered by this warranty. PACCAR is not responsible for failures or damage resulting from what PACCAR determines to be abuse or neglect, including, but not limited to: damage due to accident; operation without adequate coolants or lubricants; overfueling; overspeeding; lack of maintenance of lubricating, cooling or intake systems; improper storage, starting, warm-up, run-in or shutdown practices; failure to perform regeneration in a timely manner; unauthorized modifications of the engine. PACCAR is also not responsible for failures caused by incorrect oil or fuel or diesel exhaust fluid or by water, dirt or other contaminants in the fuel, oil, or diesel exhaust fluid. Failure of replacement parts used in repairs due to the above non-warrantable conditions is not warrantable. This warranty does not apply to accessories supplied by the vehicle original equipment manufacturer (OEM) which are covered by the OEM vehicle warranty. Failures resulting in excessive oil consumption are covered for the duration of the coverage or 250,000 miles (400,000

kilometers) or 6,250 hours from the date of delivery of the engine to the first purchaser or first lessee, whichever occurs first.

Before a claim for excessive oil consumption will be considered, the owner must submit adequate documentation to show that consumption exceeds PACCAR published standards.

Failures of belts and hoses supplied by PACCAR are covered for the first year from the date of delivery of the engine to the first purchaser or first lessee.

Parts used to repair a warrantable failure may be new parts, approved rebuilt parts, or repaired parts. PACCAR is not responsible for failures resulting from the use of parts not approved by PACCAR. A new approved or rebuilt part used to repair a warrantable failure assumes the identity of the part it replaced and is entitled to the remaining coverage hereunder.

PACCAR is not responsible for damage or loss resulting from engine horsepower/torque upgrades.

PACCAR reserves the right to interrogate electronic control module (ECM) data for purposes of failure analysis.

PACCAR does not warrant antifreeze, lubricants, filters, filter elements, or any other part which is considered a maintenance item. PACCAR does not

warrant services to remove ash from the DPF either at or before a regular service interval as indicated in the maintenance schedule or when the system indicates that the DPF requires cleaning unless the service is required as part of a warrantable repair.

**PACCAR DOES NOT COVER WEAR OR WEAROUT OF COVERED PARTS. THIS WARRANTY AND THE EMISSION WARRANTY SET FORTH HEREINAFTER ARE THE SOLE WARRANTIES MADE BY PACCAR IN REGARD TO THESE ENGINES.**

**THIS LIMITED WARRANTY IS THE SOLE WARRANTY MADE BY PACCAR AND THE SELLING DEALER. EXCEPT FOR THE ABOVE LIMITED WARRANTY, PACCAR AND THE SELLING DEALER MAKE NO OTHER WARRANTIES, EXPRESS OR IMPLIED. PACCAR AND THE SELLING DEALER EXPRESSLY DISCLAIM ANY WARRANTY OF MERCHANTABILITY OR WARRANTY OF FITNESS FOR A PARTICULAR PURPOSE.**

**PACCAR AND THE SELLING DEALER SHALL NOT BE LIABLE FOR INCIDENTAL OR CONSEQUENTIAL DAMAGES INCLUDING, BUT NOT LIMITED TO: LOSS OF INCOME OR**

**LOST PROFITS; ENGINE OR VEHICLE DOWNTIME; THIRD PARTY DAMAGE, INCLUDING DAMAGE OR LOSS TO OTHER ENGINES, VEHICLES OR PROPERTY, ATTACHMENTS, TRAILERS AND CARGO; LOSS OR DAMAGE TO PERSONAL CONTENTS; COMMUNICATION EXPENSES; LODGING AND/OR MEAL EXPENSES; FINES; APPLICABLE TAXES OR BUSINESS COSTS OR LOSSES; ATTORNEYS' FEES; AND ANY LIABILITY YOU MAY HAVE IN RESPECT TO ANY OTHER PERSON OR ENTITY.**

This warranty gives you specific legal rights, and you may also have other rights which vary from state to state.

### **Engine Warranty for Fire Apparatus Truck Applications**

This warranty applies to new PACCAR MX-13 engines sold and used in the United States<sup>41</sup> or Canada and operated in fire apparatus truck applications.

The PACCAR MX-13 engine is warranted directly to the first purchaser or first lessee by PACCAR.

### **Base Engine Warranty**

The base engine warranty covers any failures of the engine which result, under normal use and service, from a defect in material or factory workmanship (warrantable failure). This coverage begins on the date of delivery to the first purchaser or first lessee and ends after five years or 100,000 miles (160,000 kilometers), whichever occurs first.

### **PACCAR and Owner Responsibilities**

#### **PACCAR Responsibilities**

PACCAR will pay for all parts and labor needed to repair the damage to the engine resulting from a warrantable failure.

PACCAR will pay for the lubricating oil, antifreeze, filter elements, belts, hoses, and other maintenance items that are not reusable due to the warrantable failure. PACCAR will pay for reasonable labor costs for engine removal and reinstallation when necessary to repair a warrantable failure.

PACCAR will pay during the base engine warranty period of two years or 100,000 miles (160,000 kilometers), whichever occurs first: reasonable costs for towing a vehicle disabled by a warrantable failure to the nearest authorized repair location. In lieu of the towing expense and in its sole discretion, PACCAR may pay reasonable costs for a mechanic to travel to and from the location of the vehicle when an engine repair is performed at the site of the failure.

#### **Owner Responsibilities**

The owner is responsible for the operation and maintenance of the engine as specified in the applicable PACCAR Operator's Manual. The owner is also responsible for providing proof that all recommended maintenance has been performed.

Before the expiration of the applicable warranty, the owner must notify a PACCAR authorized engine dealer of any warrantable failure and make the engine available for repair by such facility. The warrantable failure must be brought to the attention of a PACCAR authorized engine dealer within 30 days of discovery. Except

for engines disabled by a warrantable failure, owner must also deliver the engine to the repair facility.

The owner is responsible for the cost of lubricating oil, antifreeze, filter elements and other maintenance items provided during warranty repairs unless such items are not reusable due to the warrantable failure. The owner is responsible for communication expenses, meals, lodging and similar costs incurred as a result of a warrantable failure.

The owner is responsible for non-engine repairs and for "downtime" expenses, cargo damage, fines, all applicable taxes, all business costs and other losses resulting from a warrantable failure. The owner is responsible for a \$100 (U.S. Dollars) deductible per each service visit under this plan in the 3rd, 4th, and 5th years of base engine warranty. The deductible will not be charged during the first two years of the base engine warranty.

#### **Warranty Limitations - Fire Truck**

Your sole and exclusive remedy against PACCAR and the selling dealer arising from your purchase and use of this engine

---

<sup>41</sup> United States includes American Samoa, the Commonwealth of Northern Mariana Islands, Guam, Puerto Rico, and the U.S. Virgin Islands.

is limited to the repair or replacement of “warrantable failures” at authorized United States and Canadian PACCAR engine dealers, or an authorized PACCAR engine facility where applicable, subject to PACCAR’s time, mileage, and hour limitations of the engine warranty. The maximum time, mileage and hour limitations of the engine warranty begin running on the date of delivery to the first purchaser or first lessee. The accrued time, mileage, or hours is calculated when the engine is brought into an authorized dealer for correction of warrantable failures.

Failures, other than those resulting from defects in material or factory workmanship, are not covered by this warranty. PACCAR is not responsible for failures or damage resulting from what PACCAR determines to be abuse or neglect, including, but not limited to: damage due to accident; operation without adequate coolants or lubricants; overfueling; overspeeding; lack of maintenance of lubricating, cooling or intake systems; improper storage, starting, warm-up, run-in or shutdown practices; failure to perform regeneration in a timely manner; unauthorized modifications of the engine. PACCAR is also not responsible for failures caused by incorrect oil or fuel or

diesel exhaust fluid or by water, dirt or other contaminants in the fuel, oil, or diesel exhaust fluid. Failure of replacement parts used in repairs due to the above non-warrantable conditions is not warrantable. This warranty does not apply to accessories supplied by the vehicle original equipment manufacturer (OEM) which are covered by the OEM vehicle warranty. Failures resulting in excessive oil consumption are covered for the duration of the coverage or 100,000 miles (160,000 kilometers) from the date of delivery of the engine to the first purchaser or first lessee, whichever occurs first. Before a claim for excessive oil consumption will be considered, the owner must submit adequate documentation to show that consumption exceeds PACCAR published standards.

Failures of belts and hoses supplied by PACCAR are covered for the first year from the date of delivery of the engine to the first purchaser or first lessee.

Parts used to repair a warrantable failure may be new parts, approved rebuilt parts, or repaired parts. PACCAR is not responsible for failures resulting from the use of parts not approved by PACCAR. A new approved or rebuilt part used to repair a warrantable failure assumes the identity

of the part it replaced and is entitled to the remaining coverage hereunder. PACCAR is not responsible for damage or loss resulting from engine horsepower/torque upgrades. PACCAR reserves the right to interrogate electronic control module (ECM) data for purposes of failure analysis. PACCAR does not warrant antifreeze, lubricants, filters, filter elements, or any other part which is considered a maintenance item. PACCAR does not warrant services to remove ash from the DPF either at or before a regular service interval as indicated in the maintenance schedule or when the system indicates that the DPF requires cleaning unless the service is required as part of a warrantable repair.

**PACCAR DOES NOT COVER WEAR OR WEAROUT OF COVERED PARTS. THIS WARRANTY AND THE EMISSION WARRANTY SET FORTH HEREINAFTER ARE THE SOLE WARRANTIES MADE BY PACCAR IN REGARD TO THESE ENGINES.**

**THIS LIMITED WARRANTY IS THE SOLE WARRANTY MADE BY PACCAR AND THE SELLING DEALER. EXCEPT FOR THE ABOVE LIMITED WARRANTY, PACCAR AND THE SELLING DEALER**

**MAKE NO OTHER WARRANTIES, EXPRESS OR IMPLIED. PACCAR AND THE SELLING DEALER EXPRESSLY DISCLAIM ANY WARRANTY OF MERCHANTABILITY OR WARRANTY OF FITNESS FOR A PARTICULAR PURPOSE. PACCAR AND THE SELLING DEALER SHALL NOT BE LIABLE FOR INCIDENTAL OR CONSEQUENTIAL DAMAGES INCLUDING, BUT NOT LIMITED TO: LOSS OF INCOME OR LOST PROFITS; ENGINE OR VEHICLE DOWNTIME; THIRD PARTY DAMAGE, INCLUDING DAMAGE OR LOSS TO OTHER ENGINES, VEHICLES OR PROPERTY, ATTACHMENTS, TRAILERS AND CARGO; LOSS OR DAMAGE TO PERSONAL CONTENTS; COMMUNICATION EXPENSES; LODGING AND/OR MEAL EXPENSES; FINES; APPLICABLE TAXES OR BUSINESS COSTS OR LOSSES; ATTORNEYS' FEES; AND ANY LIABILITY YOU MAY HAVE IN RESPECT TO ANY OTHER PERSON OR ENTITY.**

This warranty gives you specific legal rights, and you may also have other rights which vary from state to state.

### **Emissions Warranty**

This emission warranty applies to new PACCAR engines marketed by PACCAR that are used in the United States<sup>42</sup> in vehicles designed for transporting persons or property on a street or highway.

### **Coverage**

PACCAR warrants to the first purchaser or first lessee and each subsequent purchaser that the engine is designed, built and equipped so as to conform at the time of sale by PACCAR with all U.S. Federal emission regulations applicable at the time of manufacture and that it is free from defects in material or factory workmanship which would cause it not to meet these regulations within the longer of the following periods: (A) Five years or 100,000 miles (160,000 kilometers) of operation, whichever occurs first, as measured from the date of delivery of the

engine to the first purchaser or first lessee or (B) The base engine warranty. If the vehicle in which the engine is installed is registered in the state of California, a separate [California Emissions Control Warranty Statement](#) on page 110 also applies. See California Emissions Warranty.

### **Replacement Emissions Related Parts**

PACCAR recommends that any service parts used for maintenance, repair or replacement of emission control systems be new or genuine approved rebuilt parts and assemblies, and that the engine be serviced by an authorized PACCAR engine dealer. Your vehicle contains air, fuel, and electrical components that may affect engine emission controls. The use of non-genuine aftermarket parts, auxiliary devices or consumables (such as filters, oils, catalysts, additives, fuels, etc.) may result in failures which will not be covered under the manufacturer's warranty. PACCAR does not evaluate all aftermarket auxiliary devices, accessories or consumables promoted by other

<sup>42</sup> United States includes American Samoa, the Commonwealth of Northern Mariana Islands, Guam, Puerto Rico, and the U.S. Virgin Islands.

manufacturers and their effect on PACCAR Products. Customers who use such items assumes ALL risks related to the effects that result from this usage.

### **Warranty Limitations - Emissions**

Your sole and exclusive remedy against PACCAR and the selling dealer arising from your purchase and use of this engine is limited to the repair or replacement of “warrantable failures” at authorized United States and Canadian PACCAR engine dealers , or an authorized PACCAR engine facility where applicable, subject to PACCAR’s time, mileage, and hour limitations of the engine warranty. The maximum time, mileage and hour limitations of the engine warranty begin running on the date of delivery to the first purchaser or first lessee. The accrued time, mileage, or hours is calculated when the engine is brought into an authorized dealer for correction of warrantable failures.

Failures, other than those resulting from defects in material or factory workmanship, are not covered by this warranty. PACCAR is not responsible for failures or damage resulting from what PACCAR determines to be abuse or neglect, including, but not limited to: damage due to accident;

operation without adequate coolants or lubricants; overfueling; overspeeding; lack of maintenance of lubricating, cooling or intake systems; improper storage, starting, warm-up, run-in or shutdown practices; failure to perform regeneration in a timely manner; unauthorized modifications of the engine. PACCAR is also not responsible for failures caused by incorrect oil or fuel or diesel exhaust fluid or by water, dirt or other contaminants in the fuel, oil, or diesel exhaust fluid. Failure of replacement parts used in repairs due to the above non-warrantable conditions is not warrantable. PACCAR is not responsible for non-engine repairs, downtime expenses, cargo damage, fines, all applicable taxes, all business costs or other losses resulting from a warrantable failure. PACCAR does not warrant antifreeze, lubricants, filters, filter elements, or any other part which is considered a maintenance item. PACCAR does not warrant services to remove ash from the DPF either at or before a regular service interval as indicated in the maintenance schedule or when the system indicates that the DPF requires cleaning unless the service is required as part of a warrantable repair.

**THIS LIMITED EMISSION WARRANTY IS THE SOLE WARRANTY MADE BY PACCAR RELATING TO THE EMISSION EQUIPMENT. EXCEPT FOR THE ABOVE LIMITED WARRANTY, PACCAR MAKES NO OTHER WARRANTIES, EXPRESS OR IMPLIED. PACCAR EXPRESSLY DISCLAIMS ANY WARRANTY OF MERCHANTABILITY OR WARRANTY OF FITNESS FOR A PARTICULAR PURPOSE.**

**PACCAR AND THE SELLING DEALER SHALL NOT BE LIABLE FOR INCIDENTAL OR CONSEQUENTIAL DAMAGES INCLUDING, BUT NOT LIMITED TO: LOSS OF INCOME OR LOST PROFITS; ENGINE OR VEHICLE DOWNTIME; THIRD PARTY DAMAGE, INCLUDING DAMAGE OR LOSS TO OTHER ENGINES, VEHICLES OR PROPERTY, ATTACHMENTS, TRAILERS AND CARGO; LOSS OR DAMAGE TO PERSONAL CONTENTS; COMMUNICATION EXPENSES; LODGING AND/OR MEAL EXPENSES; FINES; APPLICABLE TAXES OR BUSINESS COSTS OR LOSSES; ATTORNEYS’ FEES; AND ANY LIABILITY YOU MAY HAVE IN RESPECT TO ANY OTHER PERSON OR ENTITY.**

3

## California Emissions Control Warranty Statement

### Your Warranty Rights and Obligations

The California Air Resources Board and PACCAR are pleased to explain the emission control system warranty on your 2021 model year diesel engine. In California, new motor-vehicle engines must be designed, built, and equipped to meet the State's stringent anti-smog standards. PACCAR must warrant the emission control system on your diesel engine for the periods of time listed below provided there has been no abuse, neglect or improper maintenance of your diesel engine.

Your emission control system may include parts such as the fuel injection system and engine electronic control module. Also included may be hoses, connectors and other emission related assemblies.

If an emission-related part on your engine is found to have a defect in material or factory the part will be repaired or replaced by PACCAR. This is your emission control system defects warranty.

Emissions coverage for on-highway applications in the State of California

This emission control system warranty applies to diesel engines (hereafter, engines) certified with the California Air Resources Board beginning with the year 2013, marketed by PACCAR, and registered in California for use in on-highway applications.

### Manufacturer's Warranty Coverage

This warranty coverage is provided for five years or 100,000 mi (160,000) km or 3,000 hours of engine operation, whichever first occurs from the date of delivery of the engine to the first purchaser or first lessee. Where a warrantable condition exists, PACCAR will repair your engine at no cost to you including diagnosis, parts and labor.

### Owner's Warranty Responsibilities

As the engine owner, you are responsible for the performance of the required maintenance listed in your PACCAR operator's manual. You are responsible for presenting your engine to an authorized PACCAR engine dealer as soon as a problem exists. The warranty repairs should be completed in a reasonable amount of time, not to exceed 30 days. PACCAR recommends that you retain all receipts covering maintenance on your engine, but PACCAR cannot deny warranty

solely for the lack of receipts or for the failure to ensure the performance of all scheduled maintenance.

As the engine owner, you should also be aware that PACCAR may deny you warranty coverage if your engine or a part has failed due to abuse, neglect, improper maintenance or unapproved modifications. If you have any questions regarding your warranty rights and responsibilities, you should contact Kenworth Truck Company 1-425-828-5000, Peterbilt Motor Company at 1-940-591-4220, or the California Air Resource Board at:

California Air Resource Board, 9528  
Telstar Avenue, El Monte, CA 91731

A warranted part which is scheduled for replacement as required maintenance is warranted up to the first scheduled replacement point.

Prior to the expiration of the applicable warranty, the owner must give notice of any warranted emission control failure to an authorized PACCAR engine dealer and deliver the engine to such facility for repair. The owner is responsible for incidental costs such as: communication expenses, meals, lodging incurred by owner or



employees of owner as a result of a warrantable condition.

The owner is responsible for downtime expenses, cargo damage, fines, all applicable taxes, all business costs, and other losses resulting from a warrantable condition.

### Replacement Parts

PACCAR recommends that any service parts used for maintenance, repair or replacement of emission control systems be new or genuine PACCAR approved rebuilt parts and assemblies, and that the engine be serviced by an authorized PACCAR engine dealer . Your vehicle contains air, fuel, and electrical components that may affect engine emission controls. The use of non-genuine engine or vehicle replacement parts that are not equivalent to the PACCAR engine or OEM vehicle manufacturer's original part may impair the engine and vehicle emissions control system from working or functioning effectively, and may jeopardize your emissions warranty coverage. The owner may elect to have maintenance, replacement or repair of the emission control parts performed by a facility other than an authorized PACCAR engine dealer and may elect to use parts other than new

or genuine approved rebuilt parts and assemblies for such maintenance, replacement or repair; however, the cost of such service or parts and subsequent failures resulting from such service or parts will not be covered under this emission control system warranty, except for *Emergency Repairs* on page 111."

### PACCAR Responsibilities

The warranty coverage begins when the engine is delivered to the first purchaser or first lessee. Repairs and service will be performed by any authorized PACCAR engine dealer using new or genuine PACCAR approved rebuilt parts and assemblies. PACCAR will repair any of the emission control parts found by PACCAR to be defective without charge for parts or labor (including diagnosis which results in determination that there has been a failure of a warranted emission control part).

### Emergency Repairs

In the case of an emergency where an authorized PACCAR engine dealer is not available, repairs may be performed by any available repair location or by any individual using any replacement parts. A part not being available within 30 days or a repair not being complete within 30 days

constitutes an emergency. PACCAR will reimburse the owner for expenses (including diagnosis), not to exceed the manufacturers suggested retail price for all warranted parts replaced and labor charges based on the manufacturers recommended time allowance for the warranty repair and the geographically appropriate hourly labor rate.

Replaced parts and paid invoices must be presented at an authorized PACCAR engine dealer as a condition of reimbursement for emergency repairs not performed by an authorized PACCAR engine dealer .

### Warranty Limitations

Your sole and exclusive remedy against PACCAR and the selling dealer arising from your purchase and use of this engine is limited to the repair or replacement of "warrantable failures" at authorized United States and Canadian PACCAR engine dealers , or an authorized PACCAR engine facility where applicable, subject to PACCAR's time, mileage, and hour limitations of the engine warranty. The maximum time, mileage and hour limitations of the engine warranty begin running on the date of delivery to the first purchaser or first lessee. The accrued

time, mileage, or hours is calculated when the engine is brought into an authorized dealer for correction of warrantable failures.

Failures, other than those resulting from defects in material or factory workmanship, are not covered by this warranty. PACCAR is not responsible for failures or damage resulting from what PACCAR determines to be abuse or neglect, including, but not limited to: damage due to accident; operation without adequate coolants or lubricants; overfueling; overspeeding; lack of maintenance of lubricating, cooling or intake systems; improper storage, starting, warm-up, run-in or shutdown practices; failure to perform regeneration in a timely manner; unauthorized modifications of the engine. PACCAR is also not responsible for failures caused by incorrect oil or fuel or diesel exhaust fluid or by water, dirt or other contaminants in the fuel, oil, or diesel exhaust fluid. Failure of replacement parts used in repairs due to the above non-warrantable conditions is not warrantable. PACCAR is not responsible for failures resulting from improper repair or the use of parts which are not genuine PACCAR approved parts.

PACCAR is not responsible for the material and labor costs of emission control parts

and assemblies replaced during Scheduled Maintenance of the engine as specified in PACCAR Operator's Manuals.

PACCAR does not warrant antifreeze, lubricants, filters, filter elements, or any other part which is considered a maintenance item. PACCAR does not warrant services to remove ash from the DPF either at or before a regular service interval as indicated in the maintenance schedule or when the system indicates that the DPF requires cleaning unless the service is required as part of a warrantable repair.

**THIS WARRANTY, TOGETHER WITH THE EXPRESS COMMERCIAL WARRANTIES ARE THE SOLE WARRANTIES MADE BY PACCAR IN REGARD TO THESE ENGINES.**

**THIS LIMITED EMISSIONS WARRANTY IS THE SOLE WARRANTY MADE BY PACCAR AND THE SELLING DEALER. EXCEPT FOR THE ABOVE LIMITED WARRANTY, PACCAR AND THE SELLING DEALER MAKE NO OTHER WARRANTIES, EXPRESS OR IMPLIED. PACCAR AND THE SELLING DEALER EXPRESSLY DISCLAIM ANY WARRANTY OF MERCHANTABILITY OR WARRANTY OF FITNESS FOR A PARTICULAR PURPOSE.**

**PACCAR AND THE SELLING DEALER SHALL NOT BE LIABLE FOR INCIDENTAL OR CONSEQUENTIAL DAMAGES INCLUDING, BUT NOT LIMITED TO: LOSS OF INCOME OR LOST PROFITS; ENGINE OR VEHICLE DOWNTIME; THIRD PARTY DAMAGE, INCLUDING DAMAGE OR LOSS TO OTHER ENGINES, VEHICLES OR PROPERTY, ATTACHMENTS, TRAILERS AND CARGO; LOSS OR DAMAGE TO PERSONAL CONTENTS; COMMUNICATION EXPENSES; LODGING AND/OR MEAL EXPENSES; FINES; APPLICABLE TAXES OR BUSINESS COSTS OR LOSSES; ATTORNEYS' FEES; AND ANY LIABILITY YOU MAY HAVE IN RESPECT TO ANY OTHER PERSON OR ENTITY.**



# Index

## A

Accessory Drive [85](#)  
Additives to Cooling System [59](#)  
After Replacing Engine Oil Filter(s) [72](#)  
Aftertreatment Exhaust Piping [33](#)  
Air Compressor [93](#)  
Air filter housing [93](#)  
Air Filter Restriction Indicator [94](#)  
Air Intake Piping [33](#)  
Air Intake System [92](#)  
Antifreeze [82](#)

## B

Batteries, Cables, and Connections [95](#)  
Belt Routing [85](#)  
Belts [85](#)  
Biodiesel [63](#), [76](#)

## C

Centrifugal Bypass Oil Filter Installation [71](#)  
Centrifugal Bypass Oil Filter Removal [71](#)  
Charge Air Cooler [93](#)  
Charge Air Piping [93](#)  
Check Engine Lamp Turns On [11](#)  
Checking Coolant Condition [82](#)  
Cleaning the Engine [32](#)  
Clutch, fan [88](#)  
Cold Weather Starting [21](#)  
Composite oil pan [68](#)

Compression Brake [17](#)  
Compression Brake Controls [17](#)  
Coolant Filter Installation [84](#)  
Coolant Level [33](#)  
Cooling Fan [33](#)  
Cooling System [82](#)  
Cooling system maintenance [59](#)  
Cooling System Overheating [12](#)  
Crank Mounted Fan [88](#)  
Crankshaft - Vibration Damper [96](#)

## D

Diesel Exhaust Fluid [34](#)  
Diesel Exhaust Fluid (DEF) Lamp [16](#)  
Diesel Exhaust Fluid filter [91](#)  
Diesel Fuel [76](#)  
Diesel Particulate Filter (DPF) Warning Light [15](#)  
Drive Belts [85](#)  
Driving [18](#)

## E

ELC [82](#)  
Electrical Harness / Cables [95](#)  
Electromagnetic Interference [23](#)  
Engine Air filter [94](#)  
Engine Belt Checks [87](#)  
Engine Braking System [16](#)  
Engine Compression Brake Level Switch Operation [18](#)  
Engine Coolant Specifications [62](#)  
Engine Cooling Recommendations and Specifications [59](#)  
Engine Fan [87](#), [88](#)

Engine is overheating [12](#)  
Engine Lubricating Oil Recommendations and Specifications [56](#)  
Engine Lubrication and Filter Intervals [57](#)  
Engine Maintenance [32](#)  
Engine Mounting Bolts [96](#)  
Engine Oil [56, 70](#)  
Engine Oil Capacities and Pressures [57](#)  
Engine Oil Filter [70, 72](#)  
Engine Oil Filter Specifications [55](#)  
Engine Oil Level [66](#)  
Engine Oil Level Check [34](#)  
Engine Oil Pressure Lamp Turns On [11](#)  
Engine Operating Range [22](#)  
Engine Shutdown [23](#)  
Engine Specifications for operator manual [54](#)  
Engine Valves [96](#)  
Engine Warning Lamps [13](#)  
Engine, Check Engine [14](#)  
Exhaust Brake [16](#)  
Exhaust System [95](#)  
Extended Life Coolant [63, 82](#)

## F

Fan Belt Tensioner [87](#)  
Fan Belts [88](#)  
Filters [70–72, 76, 77, 79](#)  
Forward [6](#)  
Fuel Filter [63, 76](#)  
Fuel Filter / Water Separator [33](#)  
Fuel Filter Installation [79](#)  
Fuel Filter Removal [77](#)  
Fuel filter, Water, Drain [81](#)  
Fuel Gelling [66](#)  
Fuel Recommendations [63](#)  
Fuel System Priming [80](#)  
Full-flow Oil Filter Installation [72](#)  
Full-flow Oil Filter Removal [72](#)

## G

General Safety Instructions [7](#)  
Greater than 20% Idle Time - 150,000 mi / 240,000 km / 4,500 hrs / 24 mo (2 yrs) [41](#)  
Greater than 20% Idle Time - 25,000 mi / 40,000 km / 750 hrs / 6 mo [39](#)  
Greater than 20% Idle Time - 300,000 mi / 480,000 km / 6,750 hrs / 36 mo (3 yrs) [42](#)  
Greater than 20% Idle Time - 350,000 mi / 560,000 km / 7,850 hrs / 48 mo (4 yrs) [42](#)  
Greater than 20% Idle Time - 450,000 mi / 725,000 km / 13,500 hrs / 48 mo (4 yrs) [43](#)  
Greater than 20% Idle Time - 50,000 mi / 80,000 km / 1,500 hrs / 12 mo (1 yr) [40](#)  
Greater than 20% Idle Time - 600,000 mi / 965,000 km / 18,000 hrs / 72 mo (6 yrs) [43](#)  
Greater than 20% Idle Time - 750,000 mi / 1,200,000 km / 24,000 hrs / 96 mo (8 yrs) [44](#)

## H

High Exhaust System Temperature (HEST) Warning Lamp [15](#)

## I

Idling in Freezing Temperatures, Extended [22](#)  
Illustrations [7](#)  
Install Fuel Filter [79](#)  
Install Oil Filter [71, 72](#)

## L

Less than 20% Idle Time - 150,000 mi / 240,000 km / 4,500 hrs / 24 mo (2 yrs) [36](#)  
Less than 20% Idle Time - 300,000 mi / 480,000 km / 6,750 hrs / 36 mo (3 yrs) [37](#)  
Less than 20% Idle Time - 37,000 mi / 60,000 km / 1,125 hrs / 6 mo [34](#)  
Less than 20% Idle Time - 375,000 mi / 600,000 km / 8,450 hrs / 48 mo (4 yrs) [37](#)  
Less than 20% Idle Time - 450,000 mi / 725,000 km / 13,500 hrs / 48 mo (4 yrs) [38](#)  
Less than 20% Idle Time - 600,000 mi / 965,000 km / 18,000 hrs / 72 mo (6 yrs) [38](#)  
Less than 20% Idle Time - 75,000 mi / 120,000 km / 2,250 hrs / 12 mo (1 yr) [35](#)  
Less than 20% Idle Time - 750,000 mi / 1,200,000 km / 24,000 hrs / 96 mo (8 yrs) [39](#)

## M

Malfunction Indicator Lamp [14](#)

## N

Normal Duty/Line Haul [34](#)

Normal Duty/Line Haul Maintenance Intervals Greater than 20% Idle Time [39](#)

Normal Duty/Line Haul Maintenance Intervals Less than 20% Idle Time [34](#)

Normal Starting Procedure [20](#)

## O

OCV Maintenance [73](#)

Oil Change [72](#)

Oil Filter [72](#)

Oil Filter Install [71](#), [72](#)

Oil Filter Removal [70–72](#)

Oil Filter Removal Preparation [70](#)

Oil Level Indication on Dipstick [67](#)

Oil Pan Drain Plug [68](#)

Oil Viscosity [56](#)

Open Crankcase Ventilation (OCV) Module Maintenance [73](#)

Open Crankcase Ventilation (OCV) System [73–76](#)

Operating on Grades and Dry Pavement [25](#)

Operating on Level and Dry Pavement [24](#)

Operating the Engine [21](#)

## P

Pick-up/Delivery/Refuse - 125,000 mi / 200,000 km / 4,500 hrs / 24 mo (2 yrs) [52](#)

Pick-up/Delivery/Refuse - 15,000 mi / 24,000 km / 400 hrs / 6 mo [49](#)

Pick-up/Delivery/Refuse - 30,000 mi / 48,000 km / 800 hrs / 12 mo (1 yr) [50](#)

Pick-up/Delivery/Refuse - 300,000 mi / 480,000 km / 9,000 hrs / 36 mo (3 yrs) [53](#)

Pick-up/Delivery/Refuse - 450,000 mi / 725,000 km / 13,500 hrs / 48 mo (4 yrs) [53](#)

Pick-up/Delivery/Refuse - 60,000 mi / 96,000 km / 1,600 hrs / 12 mo (1 yr) [51](#)

Pick-up/Delivery/Refuse - 750,000 mi / 1,200,000 km / 24,000 hrs / 96 (8 yrs) [54](#)

Pick-up/Delivery/Refuse - 90,000 mi / 144,000 km / 1,600 hrs / 12 mo (1 yr) [52](#)

Poly V-belt and Fan Drive Belts [88](#)

Poly V-belt and Fan Drive Install [89](#)

Poly V-belt, Alternator, Air-Conditioning Compressor Drive and Coolant Pump Drive Install [90](#)

Poly V-belt, Alternator, Air-Conditioning Compressor Drive and Coolant Pump Drive Removal [89](#)

Preventative Maintenance Schedule Intervals [34](#)

Priming the Fuel System [80](#)

## R

Radiator Fill Procedure [84](#)

Radiator Hoses [83](#)

Recommendations to avoid fuel gelling in cold temperatures [66](#)

Remove Fuel Filter [77](#)

Remove Oil filter [70](#)

Remove Oil Filter [71](#), [72](#)

Replace Coolant Filter [83](#)

Replace Engine Oil [72](#)

Roadside Assistance [10](#)

Run Out of Fuel [80](#)

## S

Safety [5](#)

Safety Alerts [5](#)

Severe Duty/Vocational [44](#), [49](#)

Severe Duty/Vocational - 15,000 mi / 24,000 km / 400 hrs / 6 mo [44](#)

Severe Duty/Vocational - 150,000 mi / 240,000 km / 4,500 hrs / 24 mo (2 yrs) [47](#)

Severe Duty/Vocational - 180,000 mi / 290,000 km / 5,400 hrs / 36 mo (3 yrs) [47](#)

Severe Duty/Vocational - 30,000 mi / 48,000 km / 800 hrs / 12 mo (1 yr) [45](#)

Severe Duty/Vocational - 300,000 mi / 480,000 km / 9,000 hrs / 36 mo (3 yrs) [48](#)

Severe Duty/Vocational - 450,000 mi / 725,000 km / 13,500 hrs / 48 mo (4 yrs) [48](#)

Severe Duty/Vocational - 60,000 mi / 96,000 km / 1,600 hrs / 24 mo (2 yrs) [46](#)

Severe Duty/Vocational - 750,000 mi / 1,200,000 km / 24,000 hrs / 96 (8 yrs) [49](#)

Starting After the Fuel Tank Has Run Dry [80](#)

Starting Procedure After Extended Shutdown or Oil Change [21](#)

Stop Engine Lamp [10](#), [14](#)

## T

Topping Up the Engine Oil [67](#)

Turbocharger [95](#)

## U

ULSD [63](#)

Ultra Low Sulfur Diesel [63](#)

Under hood air filter housing [93](#), [94](#)

## V

Valve Adjustment Interval [96](#)

Visual Inspection of Engine [34](#)

## W

Warranty and the Use of Biodiesel Fuel [65](#)

Warranty and the Use of Renewable and Other Paraffinic Diesel Fuels [65](#)

WIF, Water-In-Fuel, Fuel Filter Module [15](#)







## WARNING

Breathing diesel engine exhaust exposes you to chemicals known to the State of California to cause cancer and birth defects or other reproductive harm.

- Always start and operate the engine in a well-ventilated area.
- If in an enclosed area, vent the exhaust to the outside.
- Do not modify or tamper with the exhaust system.
- Do not idle the engine except as necessary.

For more information go to [www.P65warnings.ca.gov/diesel](http://www.P65warnings.ca.gov/diesel).

**PACCAR**<sup>inc</sup>  
Engines

P.O. Box 1518  
Bellevue, WA 98009

Y53-1181-1R1