



T680E

OPERATOR'S MANUAL

© 2017 PACCAR Inc. - All Rights Reserved. This manual illustrates and describes the operation of features or equipment that may be either standard or optional on this vehicle. This manual may also include a description of features and equipment that are no longer available or were not ordered on this vehicle. Please disregard any illustrations or descriptions relating to features or equipment that are not on this vehicle. PACCAR reserves the right to discontinue, change specifications, or change the design of its vehicles at any time without notice and without incurring any obligation. The information contained in this manual is proprietary to PACCAR. Reproduction, in whole or in part, by any means is strictly prohibited without prior written authorization from PACCAR Inc.

T680E

Safety	6
Emergency.....	16
Controls.....	22
Operation	30
Maintenance	36

Safety

Applies To T680E



This manual is for the T680E, a battery electric vehicle. This truck does not have an engine. The T680E powertrain and auxiliary components require different operating procedures and service intervals than the typical diesel powered truck.

This supplemental operator's manual provides information that is not part of the base T680 chassis. Please refer to the base chassis operator's manual for information unrelated to battery electric truck functions.

Using this Manual

Please take time to become acquainted with your vehicle by reading this operator's manual. Kenworth strongly recommends that you thoroughly read and understand the manual before operating the T680E. This manual contains useful information for the safe and efficient operation of the T680E. It also provides some service information, including safety checks and basic preventative maintenance inspections. After referencing this manual, please return it to the glovebox for the next vehicle user or new owner.



NOTE

After you have read this manual, store it in the glovebox for the next truck operator or the next owner.

Your vehicle may lack certain features or options mentioned in this manual. Therefore, you should pay close attention to the instructions that pertain

to just your vehicle. Additionally, if your vehicle is equipped with special equipment or options not discussed in this manual, consult your dealer or the manufacturer of the equipment. All information contained in this manual is based on the latest production information available at the time of publication. Kenworth Motors Company reserves the right to make changes at any time without notice.

Safety Alerts

Please read and follow all of the safety alerts contained in this manual. They are there for your protection and information. These alerts can help you avoid injury to yourself and your passengers. These instructions can also help prevent costly damage to the vehicle. Safety alerts are highlighted by the safety alert symbols and signal words such as "DANGER," "WARNING," "CAUTION," or "NOTE." Do NOT ignore any of these alerts.

Dangers



The safety message following this symbol and signal word provides a warning against operating procedures that, if not avoided, will cause injury or death. They could also cause equipment or property damage. The alert will identify the hazard, how to avoid it, and the probable consequence of not avoiding the hazard.

Warnings



The safety message following this symbol and signal word provides a warning against operating procedures that, if not avoided, could cause injury or death. They could also cause

equipment or property damage. The alert will identify the hazard, how to avoid it, and the probable consequence of not avoiding the hazard.

Cautions



The safety message following this symbol and signal word provides a caution against operating procedures that, if not avoided, could cause minor or moderate injury and equipment or property damage. The alert will identify the hazard, how to avoid the hazard, and the probable consequence of not avoiding the hazard.

Notes



The message following this symbol and the signal word provides important information that is not safety related but should be followed. The alert will highlight information that may not be obvious but is useful to your efficient operation of the vehicle.

Illustrations

Some illustrations in this manual are generic and do NOT exactly match the powertrain or parts used in your application. The illustrations can contain symbols to indicate an action required and an acceptable or unacceptable condition. The illustrations show service procedures. The procedure will be the same for all applications, although the illustration may differ.

General Safety Instructions

Important safety notices about operating and servicing your vehicle are included in this section.

California Proposition 65 Warning

- Low voltage battery posts, terminals, and related accessories contain lead and lead compounds, which are chemicals known to the State of California to cause cancer and reproductive harm. Wash hands after handling.
- Other chemicals in this vehicle are also known to the State of California to cause cancer, birth defects or other reproductive harm.

Data Recorder

California Vehicle Code – Section 9951 – Disclosure of Recording Device

Your vehicle may be equipped with one or more recording devices commonly referred to as “event data recorders”

(EDR) or “sensing and diagnostic modules” (SDM). If you are involved in an accident, the device(s) may have the ability to record vehicle data that occurred just prior to and/or during the accident. For additional information on your rights associated with the use of this data, contact:

- The California Department of Motor Vehicles – Licensing Operations Division
- <http://www.dmPage 11v.ca.gov/>

Environmental Protection Agency (EPA)

Below is information on the use and disposal of hazardous materials.

Some chemicals in the hydraulic oil, transmission oil, axle oil, coolant, propulsion battery packs, refrigerant, refrigerant lube, lead acid batteries, etc. may contaminate the environment if spilled or improperly disposed of.

Contact your local government agency for proper disposal guidelines.

A Special Word about Repairs

Before performing any repair, read and understand all safety precautions and warnings. The following is a list of general safety precautions that must be followed to provide personal safety. Failure to follow these instructions may cause injury or death. Special safety precautions are included in the procedures when they apply.



WARNING!

Do not attempt repair work without the proper training, service manuals, and tools. You could be injured, killed, or make your vehicle unsafe. Only conduct tasks that you are qualified to perform.



WARNING!

Only allow qualified service technicians to work on this vehicle. Improper practices, carelessness, or ignoring any warnings could cause death, personal injury, and equipment or property damage.



CAUTION!

The installation of electronic devices on any of the vehicle Controller Area Networks (CAN) or their associated wiring is not permitted and could adversely affect vehicle performance and cause vehicle fault codes to be recorded. These modifications could also void the vehicle warranty.

Even a well-maintained vehicle must be operated within the range of its mechanical capabilities, electrical capabilities, and load rating limits. See the Weight Ratings label on the driver's door edge.



WARNING!

Modifying your vehicle can make it unsafe. Some modifications can affect your vehicle's electrical system, stability, or other important functions. Before modifying your vehicle, check with your dealer to ensure the modification can be performed properly. Improper modifications could cause injury, death, or equipment damage.

Every new vehicle is designed to conform to all Federal Motor Vehicle Safety Standards that were applicable at the time of manufacture. Even with these safety features, continued safe

and reliable operation greatly depends upon regular vehicle maintenance.

Follow the maintenance recommendations found in the Preventative Maintenance section. This will help preserve your investment in the T680E.

Your dealer's service center is the best place to have your vehicle repaired.

Properly maintained high voltage personal protective equipment is required. If you are not a qualified mechanic for the Kenworth T680E, leave all repairs to an authorized service facility. Authorized service facilities are equipped to perform repairs safely and correctly.

Additional Sources of Information

Major component suppliers also supply operator's manuals specific to their products. Additional manuals and other pieces of literature are included in the glove box literature package.

Safe Vehicle Operation



WARNING!

Vehicle noise may be reduced in some operation modes. The vehicle operator must remain aware of nearby vehicles or pedestrians at all times. Failure to comply may result in death, injury, or property damage.

Refer to the T680 Operator's Manual for more guidance on safe driving.

Vehicle Loading

Refer to the T680 Operator's Manual for guidance on loading the vehicle.

Battery Electric Truck Parts Description

Air Compressor

The air compressor is driven by an electric motor.

Air Conditioning Compressor

The air conditioning compressor is also driven by an electric motor.

Cab Heater

The cab heater uses energy from the propulsion battery pack for the cab heating. It heats up coolant that circulates through a heater core for the cab.

Charger

This truck is equipped with a DC fast charger and has an optional AC charger. The charger is located on the driver's side on the propulsion battery pack.



CAUTION!

Use a compatible charger when charging the propulsion battery pack. Using chargers that are not listed by Meritor as compatible may negatively affect the propulsion battery pack life.

Chiller

The chiller is occasionally needed to cool the propulsion battery pack when ambient temperatures are not cool enough for circulating coolant.

Coolant Pumps

Two coolant pumps are used to circulate the coolant through several coolant loops on the T680E.

DC-DC Converter

The DC-DC converter is the battery electric truck's equivalent to a diesel truck's alternator. The DC-DC converter uses energy from the propulsion battery pack to power the low voltage components such as controllers and lights.

eAxle Differential

Each eAxle has a 3.91 differential ratio with a 2:1 wheel end ratio, resulting in a 7.82 rear axle ratio.

eAxle Transmission

Each eAxle has a 2-speed or 3-speed transmission.

Power Steering Pump

The power steering pump is driven by its own motor.

Powertrain Fan

The powertrain fan is electric and has little to no impact on the powertrain capabilities. If the electric powertrain fan is running frequently, it will slightly decrease the truck's range.

Propulsion Motor and Inverter

Each eAxle has one propulsion motor and inverter. The inverter converts DC voltage into time-averaged pulses that approximate the AC voltage needed to drive the propulsion motors.

Propulsion Battery Packs

There are several high voltage propulsion battery packs on this truck. Careful maintenance and operation is required to maximize the propulsion battery pack life.



WARNING!

The T680E contains a sealed lithium-ion high voltage battery. If the battery is disposed of improperly, there is a risk of severe burns and electric shock resulting in serious injury or death.



CAUTION!

Do not store the battery pack in ambient temperatures above 95 °F (35 °C). Permanent damage to the propulsion battery pack will occur.



CAUTION!

To prevent damage to the propulsion battery pack:

- Do not expose the vehicle to extreme ambient temperatures for extended periods.
- Do not store the vehicle in temperatures below -13 °F (-25 °C) for more than seven days.
- Do not leave the vehicle for more than 14 days where the state of charge gauge (Battery Gauge) displays a zero or near zero state of charge.



NOTE

If the outside temperature is -13 °F (-25 °C) or colder, the propulsion battery pack may freeze, and it cannot be charged or provide power to run the vehicle. Move the vehicle to a warmer location for the propulsion battery pack to thaw.

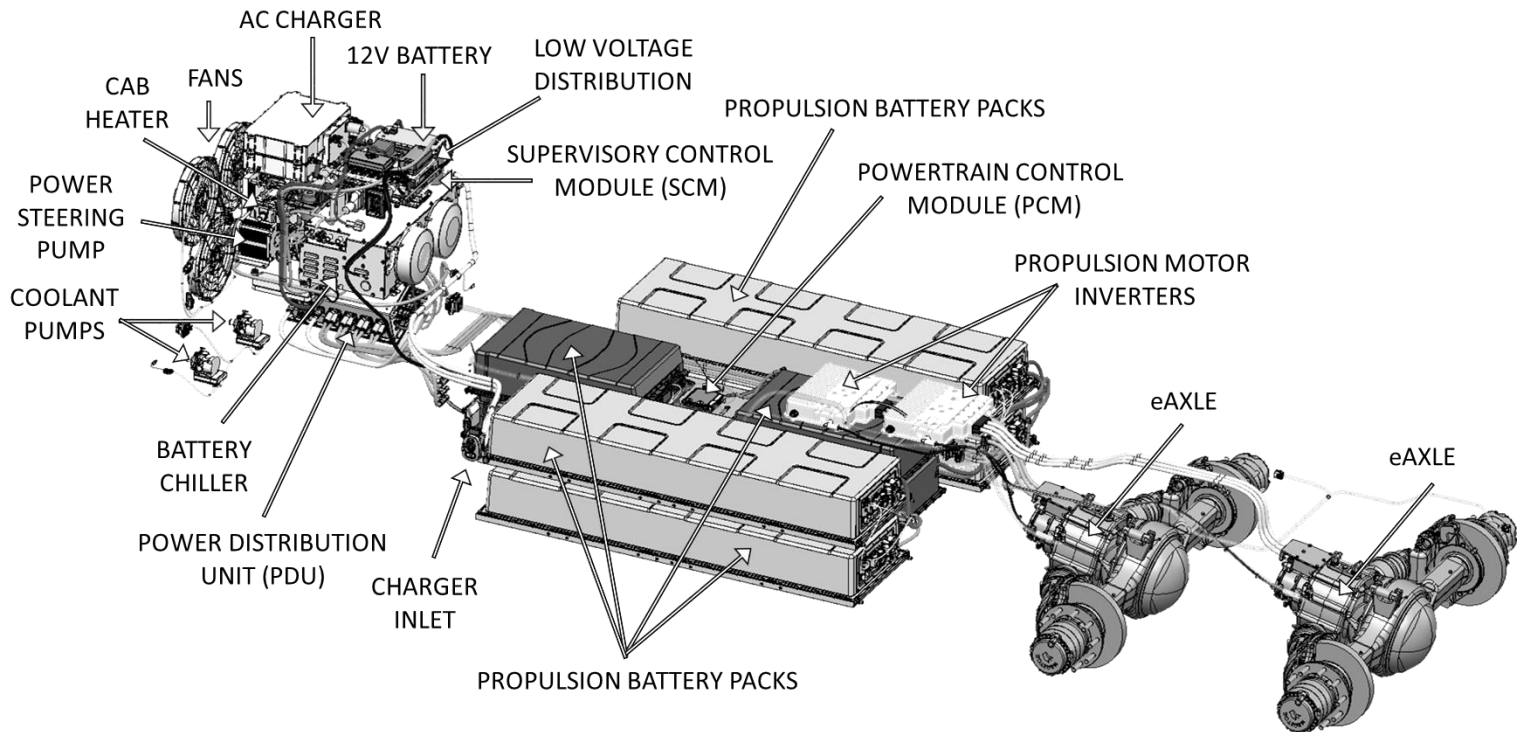

Vehicle Layout

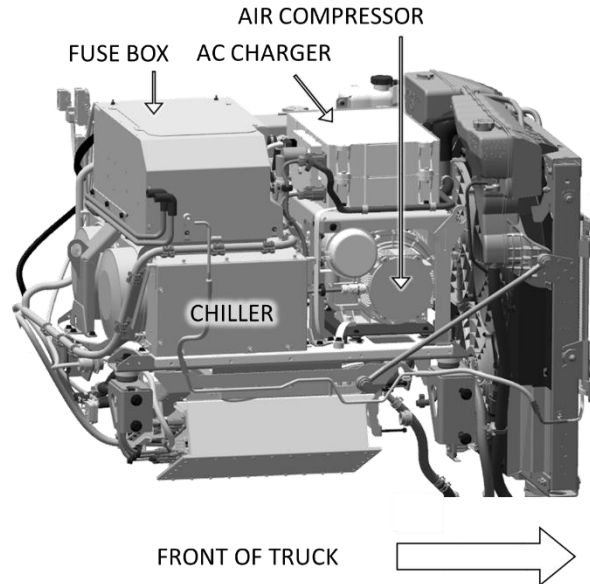
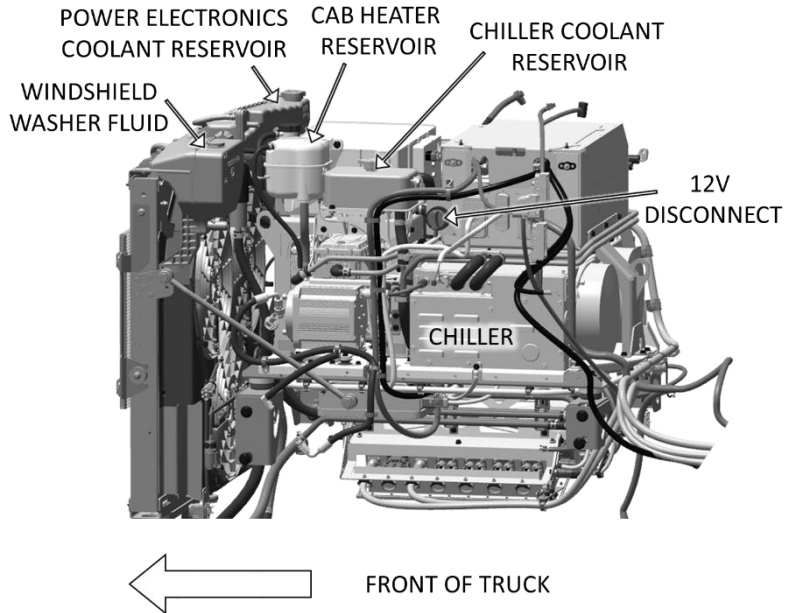

Additional Components on the PCAS

(PCAS: Power Electronics and Control Subsystem)

Emergency

Roadside Assistance

Call toll-free to talk to someone at the PACCAR Customer Center.

1-800-KW-Assist
(1-800-592-7747)

The Customer Call Center is open 24 hours a day, 365 days per year, and is staffed with trained personnel (English and other languages if necessary), free of charge, to provide total roadside assistance. Their custom mapping system can locate the nearest Authorized dealers and Independent Service Providers (ISPs) based on the vehicle's location. In addition, the customer center can dispatch services for tires, trailers, fines and permits, chains, towing, hazardous clean-up, mechanical repairs and preventive maintenance services. If they cannot answer a specific question, they will direct you to a representative who can.

First Responders Guide

First Responder instructions are available through the QR below.

Download and print the documentation for the Kenworth T680E with your current model year. Routinely check the NFPA site to ensure your first responder materials are up-to-date.



First Responders Field Guide
QR Code (Scan with Phone
Camera to Navigate to URL)

Emergency Procedures

If an accident occurs, follow the below steps:

1. If it is possible, put the truck in park and remove the key from the ignition.
2. If anyone is injured, call 911 immediately.
3. If the vehicle is on fire, do NOT try to extinguish the fire. Per NFPA guidelines, move at least 100 feet upwind of the fire.
4. Provide First Responders with the First Responders Field Guide or point first responders to the First Responders label with a QR code.

Towing



WARNING!

Do not allow the propulsion motors to spin while towing the truck. Towing the T680E (with the propulsion motors spinning) will generate unsafe voltage that could permanently damage equipment, cause personal harm, and injure bystanders.



WARNING!

Do not tow this truck after an accident if high voltage components were damaged. Refer to the first responders field guide for more instructions on towing. Failure to heed this warning could result in injury, death, or equipment damage.

The T680E can be transported on a lowboy trailer with all T680E wheels off the ground. Alternatively, call the PACCAR Customer Center for guidance on towing the truck with the drive tires on the ground.

How to Jump-Start a Battery



DANGER!

Do not connect any components to the propulsion battery packs. Only the low voltage, lead acid batteries can be used for jump-starting. Failure to heed this warning WILL result in personal injury, death, or equipment damage.



WARNING!

Never jump-start a battery near fire, flames, or electrical sparks. Batteries generate explosive gases. Keep sparks, flame, and lighted cigarettes away from the batteries. Failure to comply may result in death, personal injury, equipment or property damage.



WARNING!

Lead acid batteries contain an acid that can burn and gasses that can explode. Ignoring safety procedures may result in death, personal injury, equipment, or property damage.



WARNING!

If the low voltage, lead acid batteries are frozen. Take them into a warm location to thaw. Do NOT attempt to quickly thaw the battery packs with high temperatures. Failure to heed this warning could result in severe personal injury and equipment damage.



WARNING!

Remove all metal jewelry, metal belt buckles, etc. from yourself prior to jump-starting the vehicle. Failure to heed this warning could result in personal injury and equipment damage.



CAUTION!

Improper hook-up of jumper cables or failing to follow these instructions correctly could seriously damage all the vehicles used for jump-starting.

Jump-starting a vehicle is not recommended. However, if the low voltage battery is discharged (dead), the vehicle may start by using energy from a good low voltage battery at a similar voltage in another vehicle. This is termed jump-starting.

1. Remove any personal jewelry that may come in contact with the battery terminals.
2. Select a jumper cable that is long enough to be attached to both vehicles in a way that ensures the vehicles do not contact each other.
3. Position the two vehicles together, but do not allow them to touch.
4. Turn OFF all lights, the radio, and any other low voltage accessories on both vehicles.

5. Set the parking brakes.
6. Shift the transmission into neutral.
7. If either vehicle is equipped with battery disconnects, ensure they are in the OFF position prior to connecting the two vehicles.
8. Attach one end of a jumper cable to the positive (+) terminal of the discharged (dead) battery. This terminal may have a large red + or P on the battery case, post, or clamp.



NOTE

Always connect positive (+) to positive (+) and negative (-) to negative (-).

9. Attach the other end of the same cable to the positive (+) terminal of the good (booster) battery
10. Attach the remaining jumper cable FIRST to the negative (-) terminal (black or N) of the good battery.

11. Attach the other end of the negative cable on to a bare metal part on the truck with the dead battery.
12. If either vehicle is equipped with 12V battery disconnects, ensure that they are in the ON position.
13. Start the vehicle that has the good battery first. Let it run for 5 minutes.
14. Start the vehicle that has the discharged (dead) battery next.

If the vehicle fails to start, do not continue to turn the key in the ignition. Instead, contact the nearest authorized dealer.



WARNING!

When disconnecting the jumper cables, ensure they do not touch any bare metal and that they are not caught in any moving parts. Failure to comply may result in personal injury, death, or equipment damage.

Recovering a Vehicle



WARNING!

Always perform the vehicle shutdown steps before recovering the vehicle. Silent movement capability could exist. Failure to follow this warning could result in injury, death, or equipment damage.



WARNING!

Never place chains or straps on or across any high voltage components or orange high voltage cables. Failure to follow this warning could result in injury, death, or equipment damage.



WARNING!

When jacking or lifting a vehicle, do not place the jack or hoist on or within 12" of any high voltage components or orange high voltage cables. Failure to follow this warning could result in injury, death, or equipment damage.

Follow the steps in the first responders field guide for recovering a vehicle from a precarious position.

Fuse Replacement

Follow the steps in the T680 Operators Manual for replacing fuses. Refer to Additional Components on the PCAS for the location of the low voltage fuses for the battery electric truck components.

Controls

This section contains information on the battery electric vehicle cluster, switches, and HVAC.

For reference, the T680E cluster is shown below. Each new gauge and telltale is described in the following section. The speedometer will either have MPH or KPH as the primary unit, but otherwise remain the same.

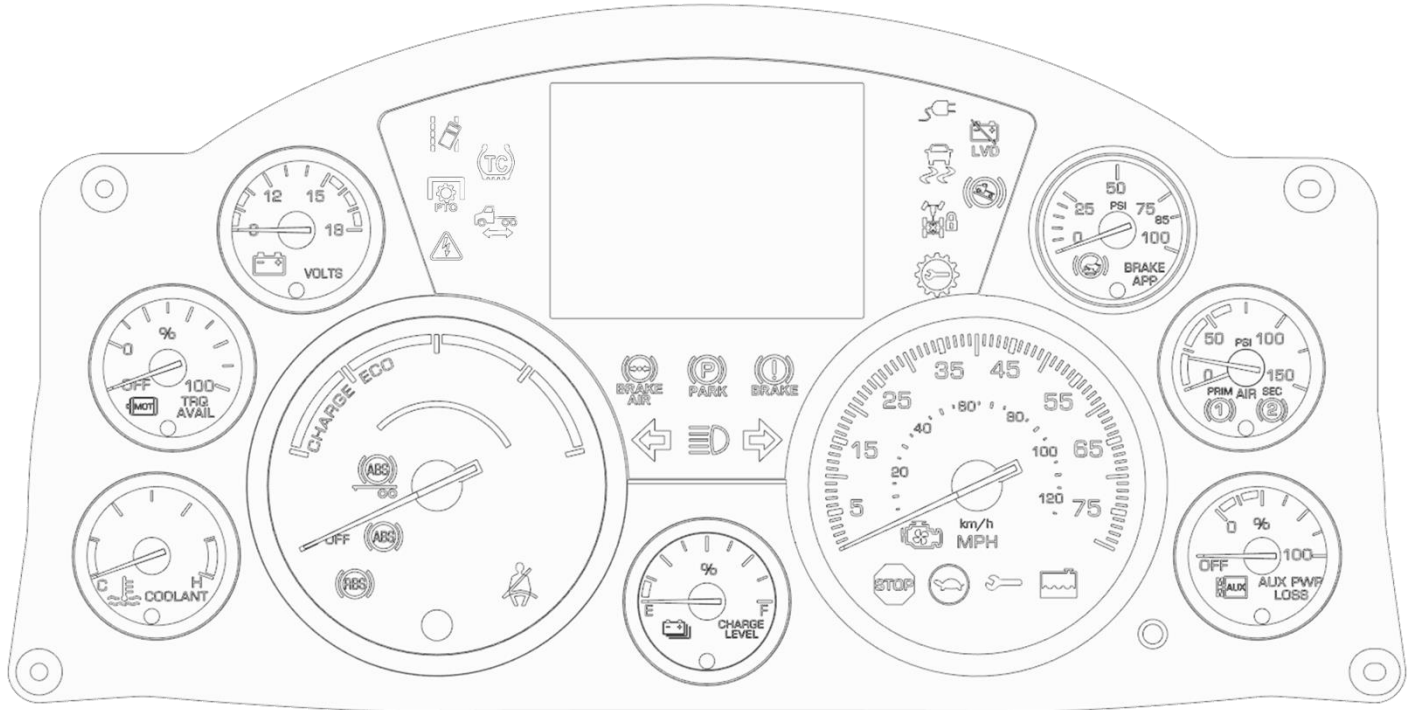

Gauges in the Center Cluster

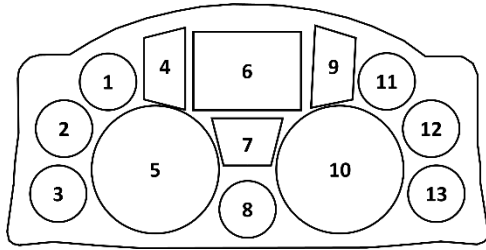

Location Descriptions:

1. Voltmeter Gauge (Low Voltage)
2. Motor Torque Available Gauge
3. Coolant Gauge
4. Telltales Only
5. Power Output Gauge
6. TFT Display
7. Telltales Only
8. Charge level Gauge
9. Telltales Only
10. Speedometer
11. Brake Application Gauge
12. Primary & Secondary Air Pressure Gauge
13. Auxiliary Power Loss Gauge

Guide to the Battery Electric Truck

Symbols

Ready to Move



Location: 4

Color: Green

Purpose:

This telltale illuminates when truck is ready to move. The truck could move if the accelerator pedal is pressed.

PTO



Location: 4

Color: Green

Purposes:

This telltale illuminates when the electric PTO (ePTO) is enabled.

External Plug Connect



Location: 9

Color: Green

Purposes:

1. This telltale illuminates when the truck is plugged into a charger.
2. This telltale flashes and an audible alarm sounds if a driver attempts to drive off while the truck is still plugged into a charger. An interlock will prevent the truck from driving off.

Service



Location: 10

Physical Telltale (Position 8 on Cluster)

Color: Amber (Yellow)

Purpose:

This telltale illuminates when the truck needs to be serviced or permanent damage could occur.

Stop Powertrain



Location: 10

Color: Red

Purpose:

This telltale illuminates when the truck needs to be pulled over. Failure to stop the truck could result injury, death, and permanent damage to the truck will occur.

Limited Performance Mode



Location: 10

Color: Amber (Yellow)

Purpose:

This telltale illuminates when the truck will be severely derated (i.e. below 25% power output allowed).

Regenerative Braking System



Location: 5

Color: Amber (Yellow)

Purpose:

RBS stands for regenerative braking system. This telltale illuminates when the regenerative braking system is severely derated or not functioning. The drive will need to rely on the foundation brakes when the RBS telltale is

illuminated. The RBS telltale can be illuminated due to normal operating conditions (e.g. high state of charge) or due to severe operating conditions (e.g. extreme temperatures, long downhill grades, etc.). If neither the Service Telltale or the Stop Sign Telltale (digital) are illuminated, the truck can continue to be driven without risk of damaging the powertrain.

High Voltage Hazard



Location: 4

Color: Red

Purpose:

This telltale illuminates when there is a high voltage hazard (e.g. High Voltage Interlock Loop Broken, Isolation Resistance Too Low, etc.). If this telltale illuminates, find a safe place to pull over, shutdown the truck, and call the PACCAR Customer Center.

Power Output Gauge

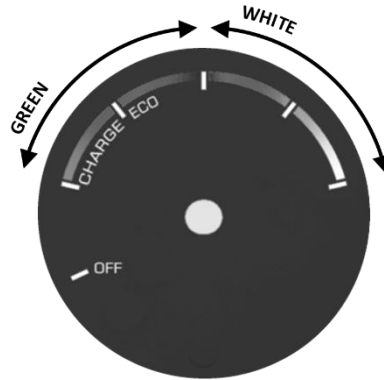

Location: 5

Purpose:

This gauge helps drivers determine if their driving is economical (ECO) or resulting in regenerative braking, charging (CHG). Driving with the needle in the green ribbon region (CHG and ECO) will result in increased range. Driving with the needle in the white ribbon region will result in lower range.

When the truck is ready to move, the needle will move between “CHG” and “ECO” and the green Ready to Move telltale will illuminate.

Battery Gauge (State of Charge)

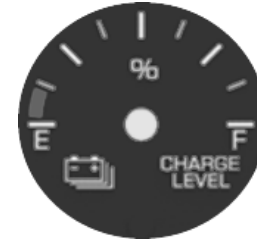

Location: 8

Purpose:

This gauge provides the propulsion battery pack’s state of charge. When the needle reaches the red region, the truck range is low, and it will enter limited performance mode soon.

Aux Loss Gauge



Location: 13

Purpose:

This gauge shows the power consumed by auxiliary components. Auxiliary component power consumption is considered any power that is not consumed by the propulsion motor. When the needle is within the green region, the truck's range should not be significantly impacted by power loss. If the gauge value is above the green region, the driver may need to consider turning off or reducing power consuming units such as the HVAC.

Motor Torque Available Gauge



Location: 2

Purpose:

This gauge shows the torque available

Virtual Gauges

All virtual gauges except the Virtual Tachometer have been disabled. The Virtual Tachometer does NOT indicate the propulsion motor speed. Do not use the Virtual Tachometer.

Trip Information Menu

Since this is a battery electric truck, the Trip Information menu will not include fuel economy information.

Truck Information Menu

The Truck Information Menu has been disabled without an option to enable it.

Heating and Air Conditioning

Heating and Air Conditioning switches have the same functions for the battery electric truck as the diesel powertrain.

Since this truck is powered by a battery electric powertrain, it does not generate enough waste heat to power the cabin heater. Instead, the propulsion battery pack's power is used to heat the cab. It will take 1-2 minutes for the truck to start generating warmer air. Using the cab heater will reduce the truck's range.

Dash Switches

Retarder Switch

Regenerative braking is used to imitate defueled engine drag and engine retarder levels with retarder functionality allowed at lower truck speeds.



NOTE

Turn the retarder switch to the ON position to enable regen braking and maximize the truck range.

Pulling the right hand stalk (RHS) toward the driver increases the retarder level, while pushing the RHS away reduces the retarder level.

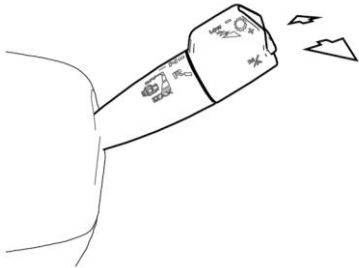

Below are the retarder switch level settings.

Level	Retarder Behavior
Off*	No regen braking
Low	Imitate defueled engine drag
Med	Medium Engine Braking Level
High	High Engine Braking Level
Max**	Highest Engine Braking Level

Notes:

* When the retarder switch is in the Off position and 0% accelerator pedal demand occurs, the truck will be coasting with no braking effort from the propulsion motors.

**The max retarder setting is a momentary switch. When the momentary switch is released, the High Engine Braking Level is used instead.



WARNING!

Turn the Retarder ON/OFF switch to the OFF position when low traction road conditions exist (e.g. ice, rain, gravel). Use the foundation brakes instead for optimal braking control. Failure to heed this warning could result in injury, death, or equipment and property damage.

Drive, Neutral, and Reverse Selector

This electric powertrain contains eAxle(s) with either 2-speed or 3-speed transmissions integrated on each eAxle.

The right hand stalk can be rotated to enter Drive, Neutral, or Reverse (see diagram below).

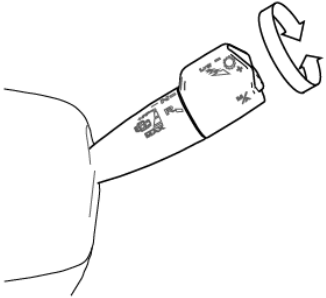

If the driver attempts to enter driver or reverse while the truck is charging, an audible alarm will sound and the green External Cord Connect telltale will flash. The charger plug must first be unplugged before the truck can be driven.

Manual Shifting

The right hand stalk can be used for manual shifting. Push the switch up or down to initiate manual shifting (see diagram below).

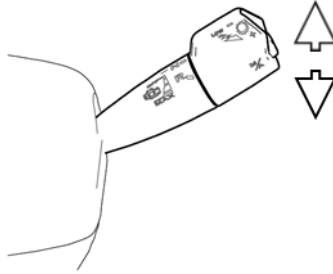

Fan Switch

Since the truck uses an electric powertrain fan that automatically runs, the fan override switch is no longer an option and will not be included.

Aftertreatment Switches

Since the truck uses a battery electric powertrain, there is no need of a Regen Aftertreatment Switch. This switch will not be included with the T680E.

Operation

Pre-Trip Inspection

Ensure the park brake is engaged and the transmission is in neutral before performing any checks.

Visual Inspection

Keep your vehicle in top operating condition before driving it. Inspect the vehicle according to the below lists.



WARNING!

Do not attempt to fix damaged high voltage components noted during the inspection. Only authorized technicians for the T680E should conduct repairs. Failure to heed this warning could result in injury, death, or damage to the vehicle.

Truck Exterior

1. Check for low hanging cables below the truck, especially, orange high voltage cables. Have an authorized technician examine any questionable components and repair them without delay.

2. Ensure the wheel cap nuts are in place and torqued properly.
3. Ensure all tire pressures match and are in the recommended pressure range.
4. Check the parking spot for evidence of any fluids leaking.
5. Verify that the truck exterior lights are all functioning.
6. Ensure all windows, mirrors, and lights are clean and unobstructed.

PCAS Inspection (Located Under Cab)



WARNING!

Do not attempt to check the coolant levels unless the powertrain is cool. Failure to heed this warning could result in personal injury due to scalding coolant.



WARNING!

Only visually inspect high voltage components. Failure to follow this warning could result in injury or death if high voltage components are loose or damaged.

1. Verify that the coolant lines, power steering lines, air lines, fittings, and other connections are all secure, intact, and free of chafing.
2. Verify that all coolant reservoirs are in the correct location and adequately filled.
3. Ensure the radiator fan is free of debris.

See Also

[Maintenance Schedule](#)

Startup

1. Remove the charger plug if necessary.
2. Turn the ignition key fully clockwise and let it spring back.
3. Ensure the retarder switch is in the ON position (unless inclement driving conditions exist) to maximize truck range.
4. Push the park brake to ensure it is released.
5. Put the truck in drive.
6. The truck will be ready to move when the green Ready to Move telltale is illuminated.



**Ready to Move Telltale
(Green)**



WARNING!

Pull over if the digital Stop Lamp is present. Continuing to discharge the battery pack after the Stop Lamp is present could permanently damage the battery pack and stop the truck unexpectedly.



WARNING!

Turn the retarder switch to the OFF position during low traction road conditions (e.g. ice, rain, gravel, etc.). Failure to turn OFF the retarder could result in uncontrolled skidding.



WARNING!

Do not assume the truck is OFF when it is silent. Check if the Ready to Move telltale is illuminated. Failure to heed this warning could result in injury or death to yourself and bystanders.



WARNING!

Vehicle noise may be reduced in some operation modes. The vehicle operator must remain aware of nearby vehicles or pedestrians at all times. Failure to comply may result in death, injury, or property damage.



NOTE

Closely monitor the cluster telltales for derate information (physical telltales) and instructions to pull over (digital Stop Sign telltale). Failure to monitor the telltales could result in permanent damage to the truck powertrain.



NOTE

Stay within the green region of the power output gauge to maximize truck range.

Shutdown

1. Put the truck in neutral.
2. Pull the park brake to ensure that it is applied.
3. Remove the key from the ignition.
4. Ensure the Ready to Move telltale is extinguished.

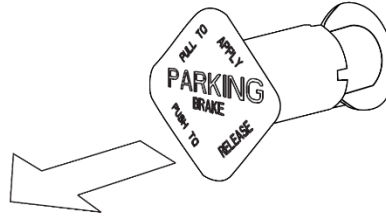

Pull to Apply Park Brake

Park Brake Position

For reference, drawings of the park brake knob in its released position (park brake disengaged) and applied position (park brake engaged) position are provided below.

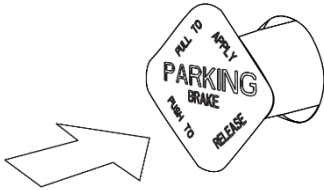

Push to Release Park Brake

Charge Port Description

The T680E has a DC fast charger and an optional AC charger. Both are SAE J1772 compliant. The CCS1 charge port is located on the driver's side on the propulsion battery pack. Use the Charge Port LED (next to the truck's charge port) and the charger screen (on the charger, not on the truck) to monitor the charging status.

Charge Port LED Status:

LED Color	Charger Status
Flashing Green	DC Fast Charging
Solid Green	Charging Complete
Flashing Green Then Flashing Yellow	AC Charging (No Errors)
Solid Yellow	Charger Plug Needs to be Reconnected
Flashing Red Then Flashing Yellow	DC or AC Charge Rate Severely Limited
Flashing Red	Charging Error

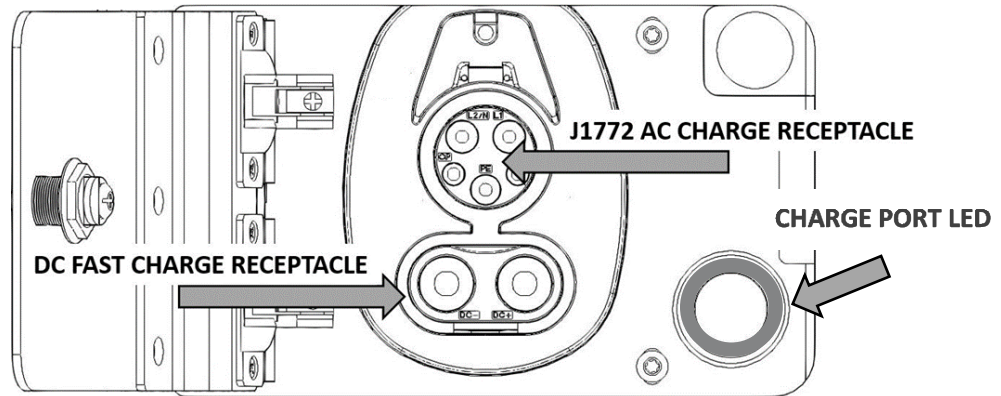

Initiating Charging



WARNING!

Ensure the park brake is engaged before connecting the truck to a vehicle charger. Failure to engage the park brake before connecting the charger cable could result in injury, death, or equipment damage.

1. Put the truck in neutral.
2. Engage the park brake.
3. Plug in the charger.
4. Wait until the charge port LED shows the DC or AC charging status (see Charge Port LED Status table).

Disconnecting Charger

The charge port LED will have a solid green illumination (no flashing) when 100% state of charge has been reached.

If you need to remove the charge plug before reaching 100% state of charge, press the Charge Port LED/button to end the charge.

If the charger plug has a button, you may need to press the charger plug button to disengage it too.

Maintenance

Daily Checks

The driver should perform these checks of the vehicle daily, at a minimum.

	NOTE
<p>These checks are in addition to, not in place of, Federal Motor Carrier Safety Regulations. These regulations may be purchased by writing to the Superintendent of Documents U.S. Government Printing Office Bookstore 710 North Capitol Street N.W. Washington, DC 20402 or ContactCenter@gpo.gov.</p>	

Powertrain

- All Coolant Levels
- Power Steering Fluid
- Low Voltage Battery Cables (**NOT the orange high voltage cables!**)
 - Check for signs of chafing or rubbing.

- Ensure all clamps or zip ties holding the cables are in good condition too.
- Hood Latch
- Brake Lines and Hoses
- Steering Components (Only visually inspect high voltage components!)

Chassis and Cab Exterior

(See T680 Operator's Manual)

Note and replace any damaged labels.

Cab Interior

(See T680 Operator's Manual for non-BEV components)

- Battery Gauge: Ensure the state of charge is high enough to complete your drive cycle.
- Cluster
 - Ensure the needles move through their full range of motion during the instrument check procedure.

- Ensure the usual telltales are illuminated during the lamp check.

Maintenance Schedule



WARNING!

Turn off the truck and wait until all radiators are cool before checking the coolant levels. Personal injury could occur if this warning is not followed.



CAUTION!

Only use the specified refrigerant lube. If the incorrect refrigerant lubricant is used, isolation errors will occur, and the truck will be inoperable.



CAUTION!

Do not mix different brands or types of lubricants. Always drain (or remove) old lubricants from the unit before refilling it. Failure to heed this warning will result in equipment damage.



WARNING!

Exercise extreme caution to prevent neckties, jewelry, long hair, or loose clothing from catching in the fan blades or any other moving parts. Failure to comply may result in personal injury, death, and equipment or property damage.



DANGER!

Restrict high voltage part maintenance to qualified personnel only. Do not touch high voltage parts or attempt to remove high voltage parts. Do not attempt to service high voltage parts. Ignoring this warning will create risk of injury or death to yourself and bystanders.



CAUTION!

Do not perform welding procedures on the truck. Welding could damage the heat treated rails, the high voltage insulation, controllers, and other expensive or safety critical components.



WARNING!

Always perform the vehicle shutdown procedure before performing routine maintenance. Otherwise, silent truck movement capability may exist.



CAUTION!

Connecting to an unapproved CAN bus may trigger CAN fault codes or worse. The truck manufacturer will not warrant failures or damage caused by improper connections to the CAN bus or improper connections.

System	Type of fluid	Capacities	Service Interval
Chiller	TRP ELC 50/50	10.5 gallons (39.7 L)	2 Years
Cab Heater		1.25 gallons (4.7 L)	
Radiator		10.25 gallons (38.8 L)	
Propulsion Battery Pack	50/50 Low Conductivity GM 12378390-DEX-Cool 50/50 Premix Coolant	To center line of reservoir sight glass	2 Years
Power Steering	EMGARD FE 75W-90	2.5 quarts (2.4 L)	First 15,000 Miles Then 120,000 Miles Or Every Year
Cab A/C	See Refrigerant Fill Label	10 ounces oil and R134a	As Needed
ePowertrain Transmission	Emgard MTF7000 40W		50,000 Miles
	Shell SPIRAX® S6 GME 40		
	Mobil Delvac1 Transmission Fluid 40		
ePowertrain Housing Diff	Castrol Syngear 75W-90	2.1 gallons (8 L) plus 1 quart (1 L) per wheel end	First 2,500 Miles Then Every 50,000 Miles

Cleaning the Vehicle



WARNING!

Perform the vehicle shutdown procedure prior to washing the truck. Failure to heed this warning could result in personal injury, death, or equipment damage.



WARNING!

Do not pressure wash the truck while it is charging. Do not pressure wash the charge port, especially not while the truck is charging. Failure to heed this warning could result in injury, death, or equipment damage.



CAUTION!

Do not power wash the PCAS. Clean the components by hand as needed.



CAUTION!

Ask the body builder for guidance on power washing any equipment added by the body builder, especially high voltage equipment.



CAUTION!

Care must be taken to avoid direct impingement on harnesses, cables, and coolant routes.

The propulsion battery pack and eAxle can be power washed.